

Main features

- Range of measurement: from 5 to 20 kN
- Accuracy class: 1%
- All stainless steel construction
- Corrosion resistant
- Grade of protection: IP65 (DIN 40050)
- Small size

The AM force transducers series have been designed to measure static and dynamic compression forces. They are particularly suitable for monitoring pounding operations in compression which require a rugged transducer, insensitive to high resonance frequencies caused by non-homogeneous loads in dynamic sequences. The accuracy and the stability are not affected by continuous cycling under harsh conditions even with dynamic loads. The small size of the AM force transducers makes them ideal for retrofitting in existing equipment.

TECHNICAL DATA

Accuracy	1%
Nominal full scale load (Ln)	5...20 kN
Nominal output at FSO	2mV/V
Output tolerance at Ln	<± 5% FSO
Combined errors: Non linearity Hysteresis, Repeatability	< ± 1% FSO
Creep (after 30 min. at Ln)	< ± 0,2% FSO
Zero load out of balance signal	< ± 1% FSO
Thermal drift in compensated range	Sensitivity Zero Calibration < ± 0,02% FSO°C < ± 0,04% FSO°C
Nominal bridge resistance	350 Ohm
Isolation resistance	> 10 GOhm
Nominal supply voltage	10 V
Maximum supply voltage	15 V
Compensated temperature range	-20...+50°C
Maximum temperature range	-20...+60°C
Storage temperature range	-30...+80°C
Permitted static load	130% Ln
Permitted dynamic load	100% Ln
Maximum applicable load	150% Ln
Rupture load	> 300% Ln
Maximum static lateral load	40% Ln
Maximum elastic deformation at Ln	< 0,2 mm
Grade of protection (DIN40050)	IP65
Electr. connections screened cable	4x0,15 / 2 m.
Elastic element material	Stainless steel

MECHANICAL DIMENSIONS

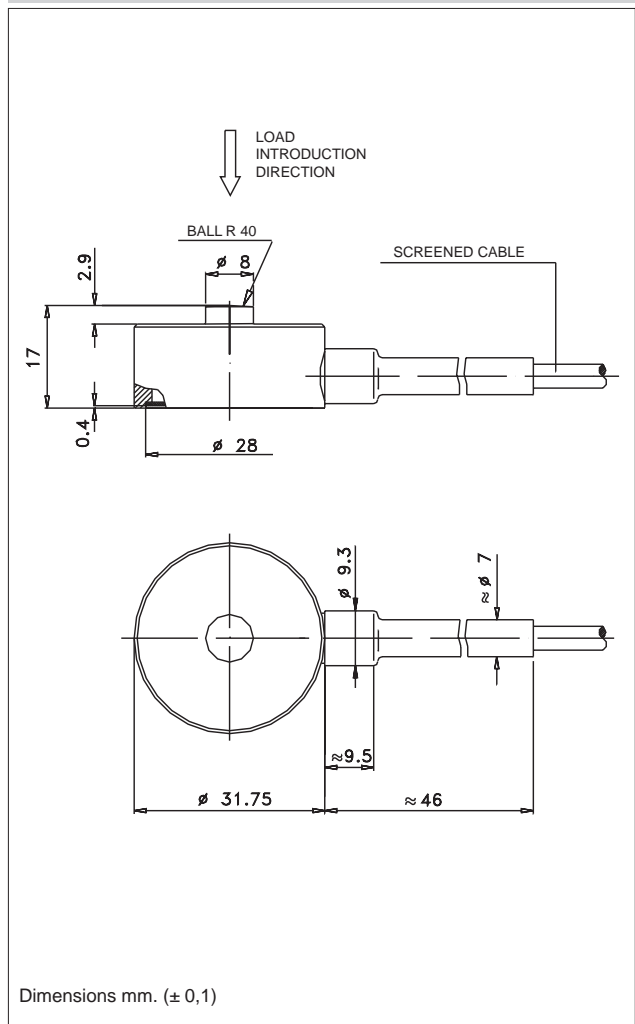

ELECTRICAL CONNECTIONS

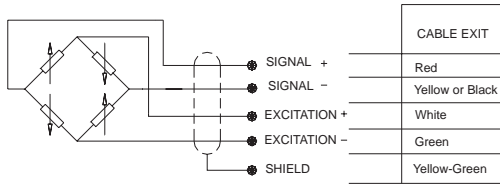

**4x0.25
Screened cable**

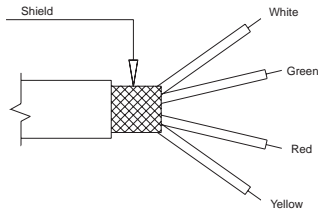

* The screen is isolated from the transducer body. It is recommended that the ground is connected at the instrument end.

Cells connected in parallel

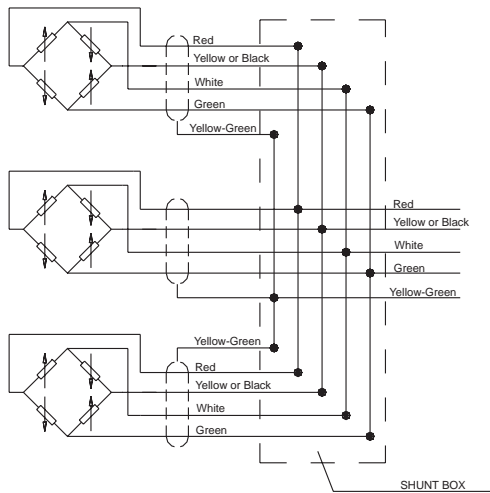

In systems that use several cells, the parallel connection automatically sums the loads on each individual cell.

Using this method of measurement, the maximum load will be the sum of the loads on the individual cells and the sensitivity will be the average value of these cells. It is important that the user ensures that no cell is stressed beyond its maximum rating under any load condition.

CONVERSION TABLE

Kg	N	Lb
1	9.807	2.205
0.102	1	0.225
0.454	4.448	1

OPTIONAL ACCESSORIES

ORDER CODE

Force transducer **AM**

MEASUREMENT RANGE (kN)	
0 - 5	KN5U
0 - 10	KN1D
0 - 20	KN2D

If request, it is possible to supply models with non-standard mechanical and/or electrical features.

Ex.: AM - KN5U

AM force transducer with range of measurement 0 - 5 kN.