



Rotary sensor for measurement ranges up to 360° with ability to program analogue versions of ±15° steps.

Contactless Hall technology for almost infinite sensor life due to absence of wear on the sensing element.

Various configurations make the product easy to install on vehicles.

High IP protection level, resistance to shock and vibration, and high electromagnetic compatibility make these products suitable for many mobile hydraulics applications.

Developed to ensure a robust and high-performance solution for applications such as agricultural machines, construction machines, material handling equipments.

TECHNICAL DATA

Measurement range

±180° different values on request programmable in steps of ±15° (ONLY for analogue versions)

Supply voltage

+5Vdc (only for 0.5...4.5Vdc output); +9...+36Vdc (see output signal for right supply voltage)

Output signal

0.5...4.5Vdc Ratiometric (supply +5Vdc); 0.5...4.5Vdc; 0...10Vdc; 4...20mA; CANopen, SAE J1939

Electrical connections

AMP Superseal 6P 282108-1; DEUTSCH 6P DT04-6P

Resolution and speed of rotation

12 bit (analog output); 14 bit (CANopen/SAE J1939 output); 120 rpm max.

Linearity

< ± 0.5% FS

Working and coefficient temperature

-40°C ... +85°C (higher values on request); thermal drift < 50 ppm/°C

Vibrations

20g - 10 Hz ... 2000 Hz IEC 60068-2-6

Shock

Impulsive on 3 axes; 50g 11 ms IEC 60068-2-27

Electromagnetic compatibility

2014/30/EU Electromagnetic Compatibility (EMC)

Life

35 M operations (stroke ±75°)

IP Protection level

IP67 - IPX9K with female mating connector mounted AMP282090-1 (GRA-A version) and mating connector DT06-6S (GRA-D version)

Housing material

PBT

MECHANICAL DIMENSIONS

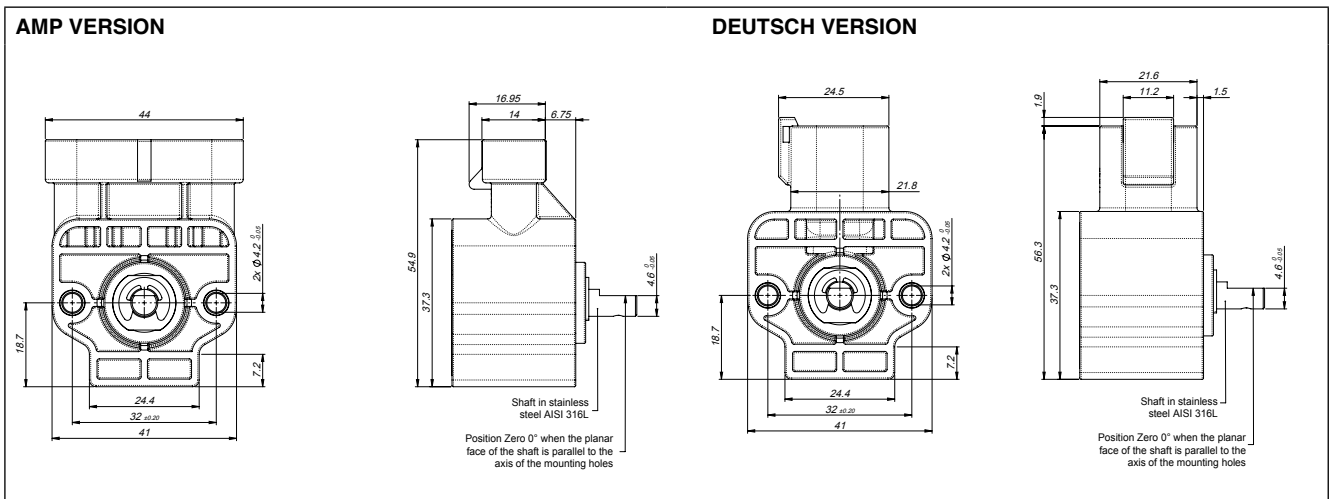

ELECTRICAL CONNECTIONS

AMP VERSION

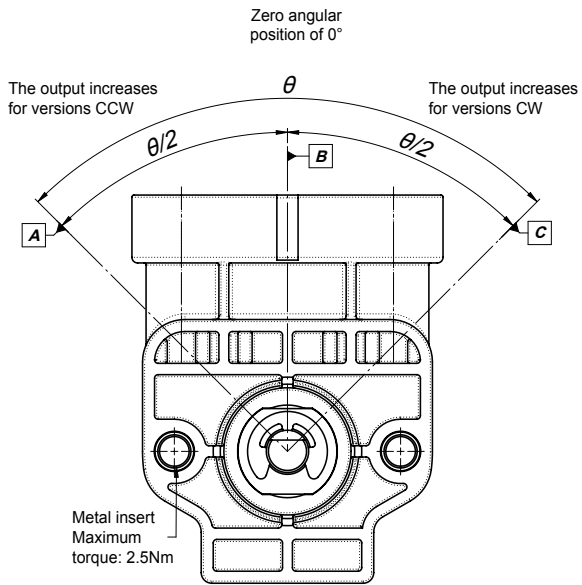

Reference	Output CW	Output CCW
A	Output : 0.5 Vdc	Output : 4.5 vdc
B	Zero angular position of 0°	Zero angular position of 0°
C	Output : 4.5 Vdc	Output : 0.5 Vdc

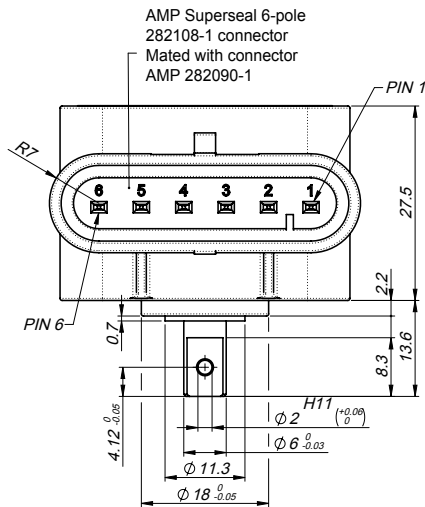

ANALOG CONNECTIONS SINGLE VERSION

1. GROUND 1
2. + SUPPLY 1
3. OUTPUT 1
4. n.c.
5. n.c.
6. n.c.

ANALOG CONNECTIONS REDUNDANT VERSION

1. GROUND 1
2. + SUPPLY 1
3. OUTPUT 1
4. GROUND 2
5. + SUPPLY 2
6. OUTPUT 2

CONNECTIONS CAN/J1939

1. GROUND
2. + SUPPLY
3. n.c.
4. n.c.
5. CAN-L
6. CAN-H

ITEMS MARKED "n.c." MUST NOT BE CONNECTED

DEUTSCH VERSION

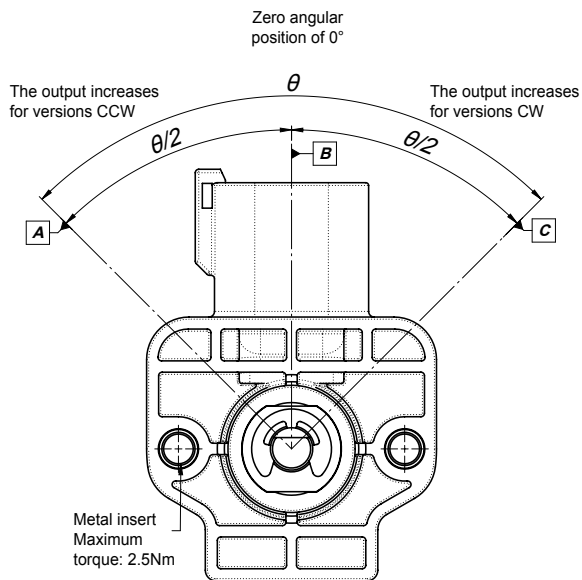

Reference	Output CW	Output CCW
A	Output : 0.5 Vdc	Output : 4.5 vdc
B	Zero angular position of 0°	Zero angular position of 0°
C	Output : 4.5 Vdc	Output : 0.5 Vdc

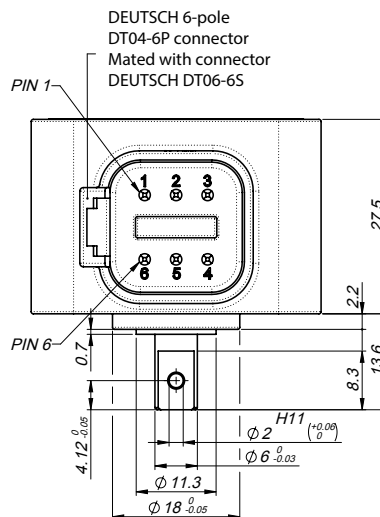

ANALOG CONNECTIONS SINGLE VERSION

1. GROUND 1
2. + SUPPLY 1
3. OUTPUT 1
4. n.c.
5. n.c.
6. n.c.

ANALOG CONNECTIONS REDUNDANT VERSION

1. GROUND 1
2. + SUPPLY 1
3. OUTPUT 1
4. GROUND 2
5. + SUPPLY 2
6. OUTPUT 2

CONNECTIONS CAN/J1939

1. GROUND
2. + SUPPLY
3. n.c.
4. n.c.
5. CAN-L
6. CAN-H

ITEMS MARKED "n.c." MUST NOT BE CONNECTED

FUNCTIONS: SENSOR OUTPUT GRAPH

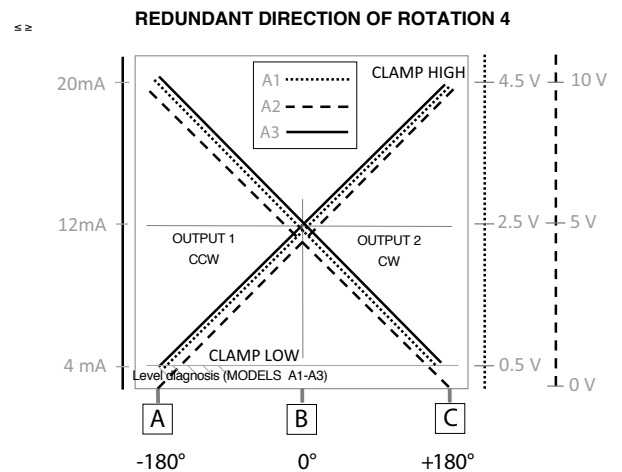
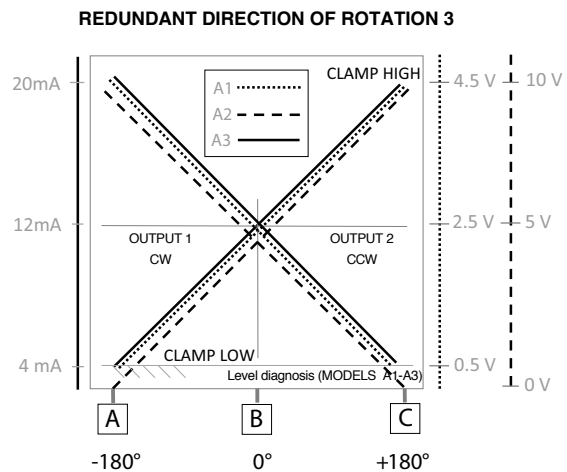
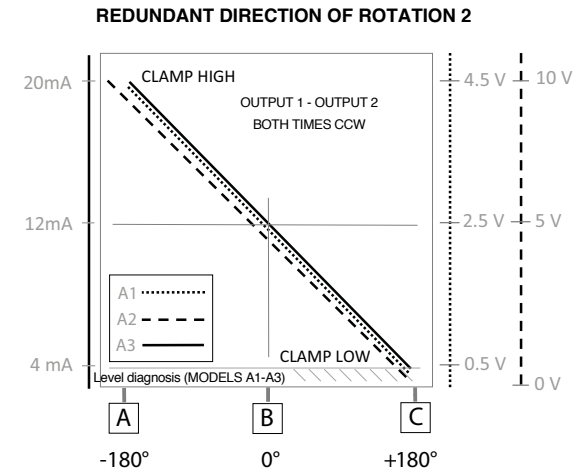
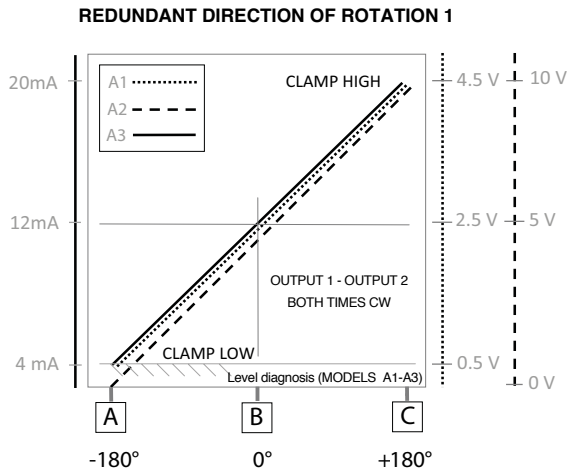
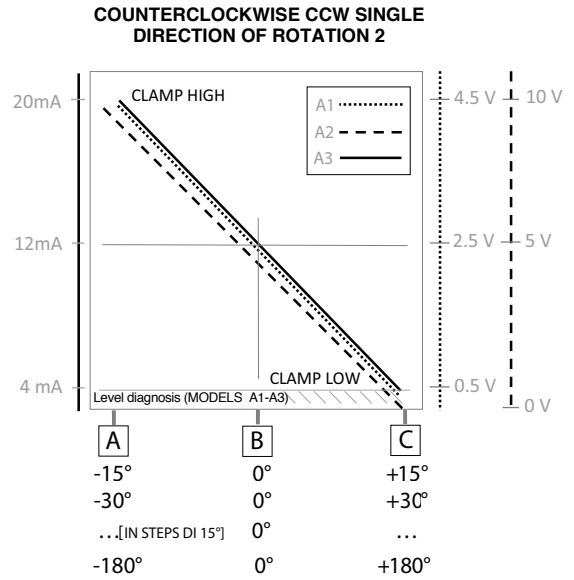
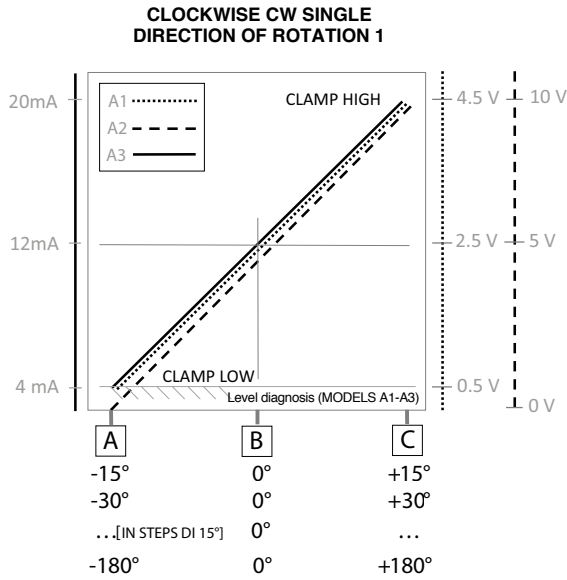

LOAD CONDITIONS

+0.5Vdc...+4.5 Vdc output with power +9...+36Vdc and +0...10Vdc output with power +11...36Vdc: it is recommended a load resistance > 100 K Ω

+0.5Vdc...+4.5 Vdc output with power +5 Vdc: it is recommended a load resistance > 10 K Ω

+4...20 mA output with power < + 15...36Vdc: the maximum load resistance is admissible 200 Ω

+4...20 mA output with power > + 15...36Vdc: the maximum load resistance is admissible 500 Ω

ORDERING CODE

ELECTRICAL CONNECTIONS

AMP Superseal 6P connector output	A
Deutsch 6P connector output	D

CIRCUIT TYPE

Single	S
Redundant (only for analog outputs)	R

ANGLE/CHANNEL 1 (output for single channel)

(analogue output A1-A2-A3 programmable in steps of $\pm 15^\circ$)	xxx
---	------------

ANGLE/CHANNEL 2 (only for redundant versions)

(analogue output A1-A2-A3 programmable in steps of $\pm 15^\circ$)	xxx
---	------------

SUPPLY VOLTAGE

+5Vdc (only for A1 output)	L
+9...+36Vdc (see output signal for right supply voltage)	H

OUTPUT TYPE

+0.5...+4.5Vdc output (available with supply L = ratiometric output and with supply H = 0.5...4.5Vdc output)	A1
0...+10Vdc output (powered at +11...36Vdc)	A2
4...20mA output (powered at +9...36Vdc)	A3
CANopen output (powered at +9...36Vdc) (available in single version with $\pm 180^\circ$ measurement range)	C1
SAE J1939 (powered at +9...36Vdc) (available in single version with $\pm 180^\circ$ measurement range)	C2

ROTATION DIRECTION

clockwise CW (single) both clockwise CW (redundant or CAN/J1939)	1
counterclockwise CCW (single) both counterclockwise CCW (redundant or CAN/J1939)	2
CHANNEL 1 clockwise CW and CHANNEL 2 counterclockwise CCW (only for redundant version and CAN/J1939)	3
CHANNEL 1 counterclockwise CCW and CHANNEL 2 clockwise CW (only for redundant version and CAN/J1939)	4

ACTUATOR

Shaft	A
-------	----------

CERTIFICATE

0	No certificate attached
L	Linearity curve to be attached

ACCESSORIES

X	No accessories
----------	----------------

ORDERING CODE

EXAMPLE OF DESCRIPTION: GRAAS180000HC14A00 0000X00

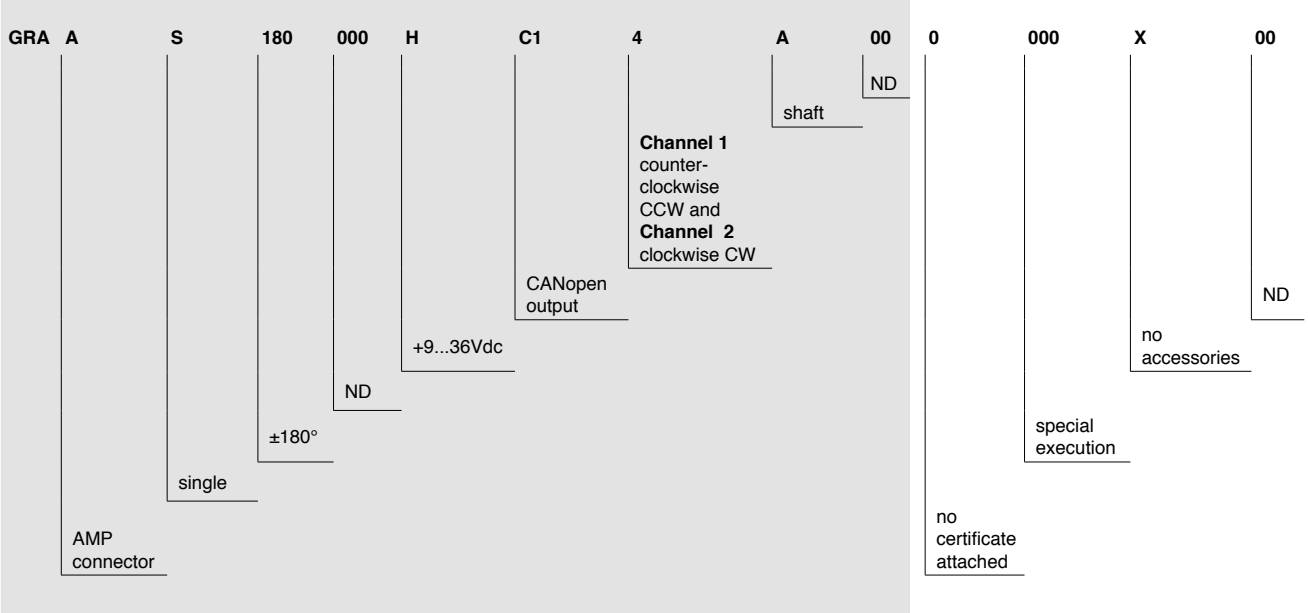

GEFRAN spa reserves the right to make any kind of design or functional modification at any moment without prior notice