

MK4 P (with ONDA technology)

CONTACTLESS MAGNETOSTRICTIVE LINEAR POSITION TRANSDUCER

(PROFIBUS OUTPUT)



Main features

- ONDA technology
- Stroke: 50 to 4000mm
- Position resolution settable via software up to 1 μm
- Speed resolution up to 0.25 mm/sec
- Conforms to CE directives (EN 50081-1 50082-1)
- Vibration-resistant (DIN IEC68T2/6 12 g)
- IP67 protection rating
- Controls up to four cursors simultaneously
- Two M12 connectors for simplified connection to Profibus and one M8 connector for separate connection to power supply (transducer can be powered without having to be connected to bus)
- Local intelligence
- Profibus DPV0 interface on RS485 in conformity to IEC 61158

Contactless absolute linear position transducer with ONDA magnetostrictive technology. The Profibus fieldbus interface integrates in complex systems with long communication distances, guaranteeing rapid and secure data transmission.

The absence of contact on the cursor eliminates all wear and ensures almost unlimited life of the transducer.

Its many advantages include smaller size for easier installation, high protection rating for use in harsh environments, excellent linearity, repeatability, and resistance to vibration and shock, guaranteeing exceptional reliability.

TECHNICAL DATA

Model	50 to 4000 mm
Measurement taken	Position / Speed
Position read sampling time (typical)	1 ms
Shock test DIN IEC68T2-27	100g - 11ms - single blow
Vibrations DIN IEC68T2-6	12g / 10...2000Hz
Shift speed	≤ 10 m/s
Max. acceleration	≤ 100 m/s ² shift
Resolution	up to 1 μm
Cursor type	Sliding cursor Separate floating cursor
Work temperature	-40...+85°C
Storage temperature	-40...+100°C
Coefficient of temperature	20ppmFS / °C
Protection rating	IP67

ELECTRICAL DATA

Output signal	Profibus DPV0 on RS485
Rated power supply	10-32 Vdc
Max power supply ripple	1Vpp
Max. draw	2W
Min. load on output	RS485 standard
Electrical isolation	500V (*) (D.C. power supply/ground)
Polarity inversion protection	YES
Overvoltage protection	YES
Self-resetting internal fuse	YES

(*) Uses 50V 2J snubber

ELECTRICAL / MECHANICAL DATA

Model		50	75	100	130	150	175	200	225	250	300	350	360	400	450	500	550	600	650	700	750	800	850	900	950	1000			
											1100	1200	1250	1300	1400	1500	1750	2000	2250	2500	2750	3000	3250	3500	3750	4000			
Electrical Stroke (E.S.)	mm	Model																											
Independent linearity	±%F.S	Typical : $\leq \pm 0.01$ %FS (min ± 0.060 mm) with sliding cursor Typical : $\leq \pm 0.02$ % FS with floating cursor (value depends on distance between cursor and sensor body)																											
Max. dimensions (A)	mm	Model + 181.7																											
Repeatability	mm	< 0.01 (limited by resolution of output value)																											
Hysteresis	±%F.S	< ± 0.005 % FS (0.010 mm minimum)																											
Sampling time	ms	1 (for strokes up to 800) 2 (for strokes from 850 to 2000) 4 (for strokes >2000) (*)																											
* Note: the sampling time doubles for models using 3 and 4 cursors																													

MECHANICAL DIMENSIONS

Version MK4PW with sliding magnetic cursor

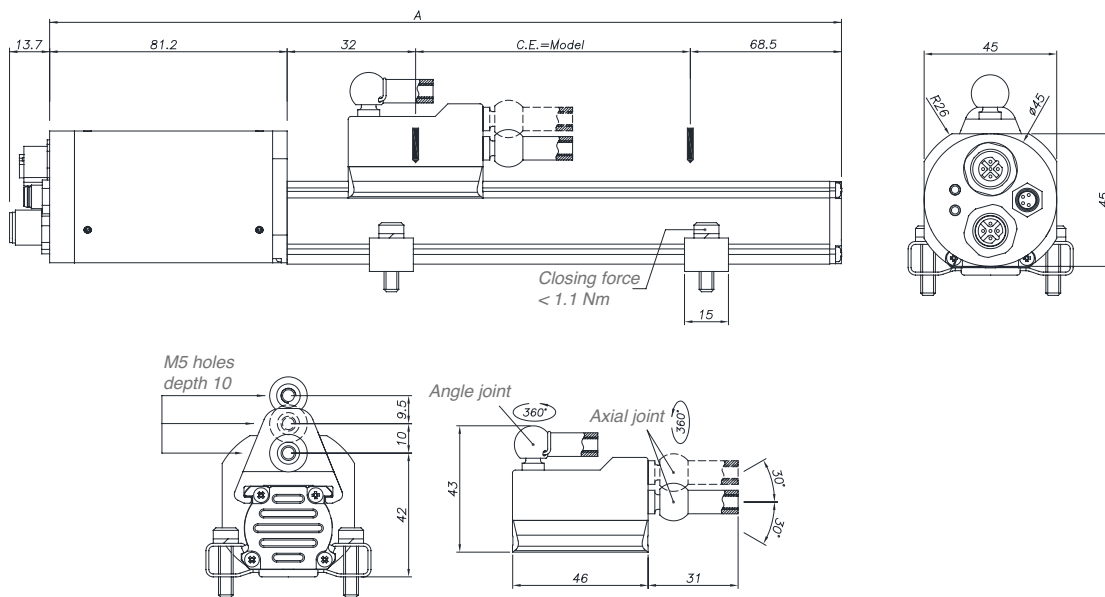

Version MK4PW with floating magnetic cursor

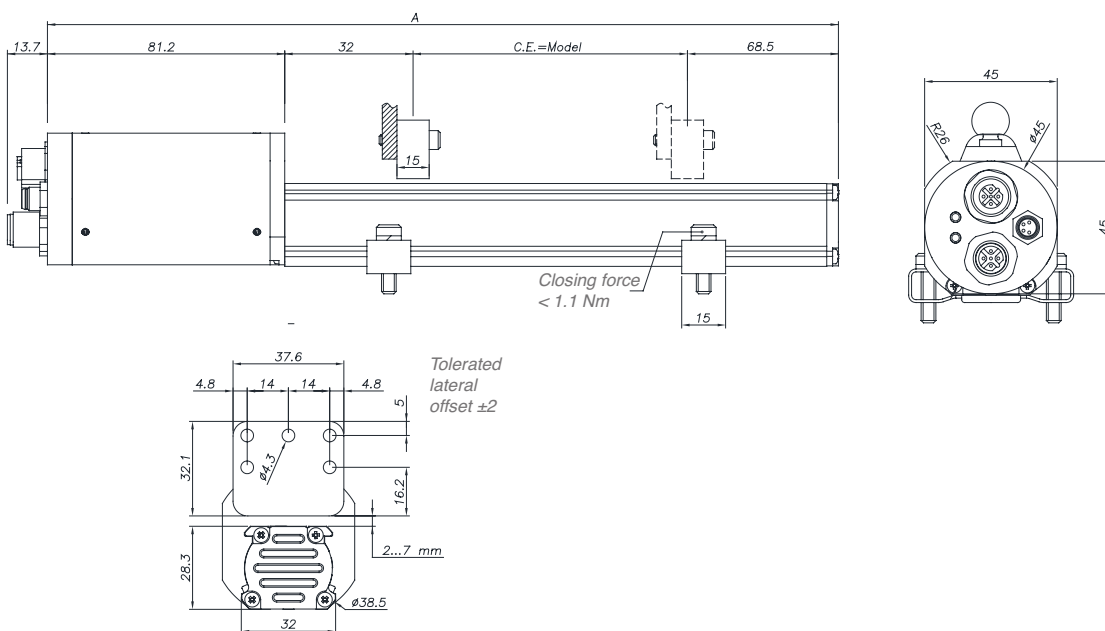

Note

- 1) For strokes > 2500mm use sliding or floating cursors at a max. height of 4mm
- 2) On multicursor versions, the cursors must work at the same distance and temperature and be at least 75 mm apart

PROFIBUS STRUCTURE AND CONNECTION

MK4PW OUTPUT

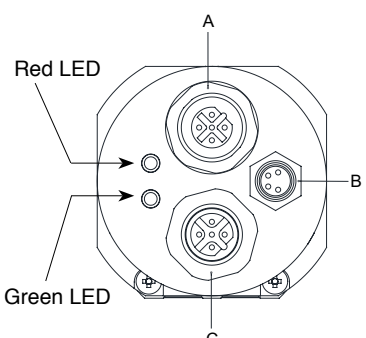

CONNECTOR A (M12 FEMALE)	
1	5VD_ISO
2	LINE_A/N
3	GND_ISO
4	LINE_B/P
5	GROUND

CONNECTOR B (M8 MALE)	
1	24V
2	N.C.
3	0V
4	N.C.

CONNECTOR C (M12 MALE)	
1	5VD_ISO
2	LINE_A/N
3	GND_ISO
4	LINE_B/P
5	GROUND

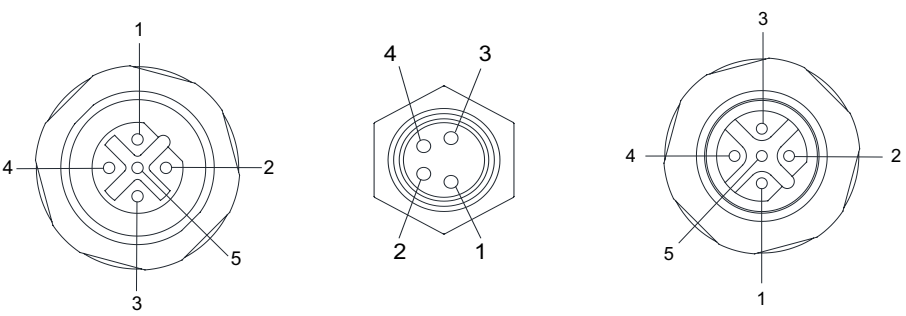

RED LED	GREEN LED	DESCRIPTION
Off	Off	Transducer not powered
Off	Flashing (f= 1 HZ)	Transducer ready to start communicating with Master (state =Wait Parm)
Off	On	Transducer in cyclical communication with Master (state= Data_Exch).
On	On	1. At power-on: signals correct functioning of LEDs. 2. In Data-Exchange mode: signals magnet error (number of magnets measured incompatible with current parameterization).

PROFIBUS STRUCTURE AND CONNECTION

A Profibus network lets you connect peripheral Slave devices (transducers or actuators) to Class 1 Master central control units (typically PLCs).

The network software is installed with a Class 2 Master containing a database with the GSD files of all connected devices. The network is designed and parameterized with a graphics tool, then the configuration is downloaded to the Class 1 Masters in the network.

The Class 1 Master(s) start(s) the communication process with the peripheral devices according to the configuration received from the Class 2 Master.

This process includes an initial data exchange regarding Slave identification, parameterization, and configuration.

When this phase is done, application management begins with exchange of process data on the network.

The GSD file contains all information on device identification, supported functions, and length/format of data packets.

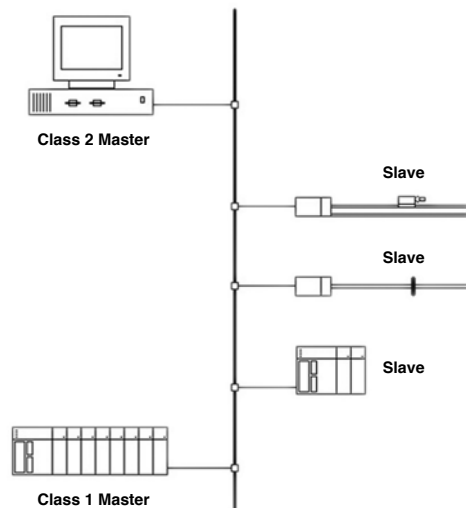

Connection with two M12 connectors + 1 M8 connector:

- no T connection required
- standard M12 and M8 connectors
- separate power supply line (ideal for use of programmer)
- for power supply: use a shielded cable with metal connector and shield connected to connector case

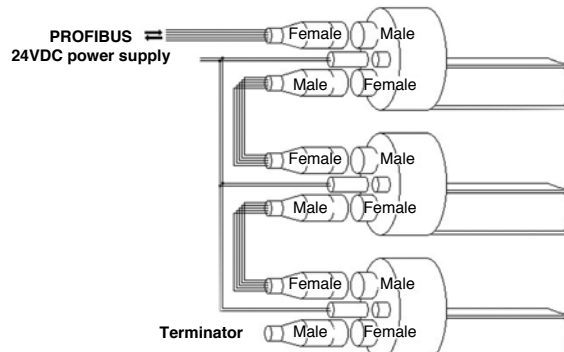

OPTIONAL CABLES

M8 4-pin axial female connector, pre-wired with 3-meter cable for power supply	PCAV700
M8 4-pin axial female connector, pre-wired with 5-meter cable for power supply	PCAV701
M12 5-pin axial female connector, pre-wired with 3-meter cable for communication	PCAV702
M12 5-pin axial female connector, pre-wired with 5-meter cable for communication	PCAV704
M12 5-pin axial male connector, pre-wired with 3-meter cable for communication	PCAV703
M12 5-pin axial male connector, pre-wired with 5-meter cable for communication	PCAV705

OPTIONAL ACCESSORIES

Profibus terminator (M12 axial male connector)	CON049
M12 5-pin axial male flying connector	CON380
M12 5-pin axial female flying connector	CON390
Node number programmer	PNP-1
GSD file downloadable from www.gefran.com	

OPTIONAL NODE NUMBER PROGRAMMER

The PNP-1 node number programmer lets you read and set the node number on a Profibus network for MK4-P and IK4-P series sensors.

This accessory component is used if you do not have a Class 2 Master programmer.

See the PNP-1 programmer technical sheet and manual for detailed information.

