

## HORIZONTAL PUMPS

Magnetic drive

M10 .. M15 - PP/PVDF

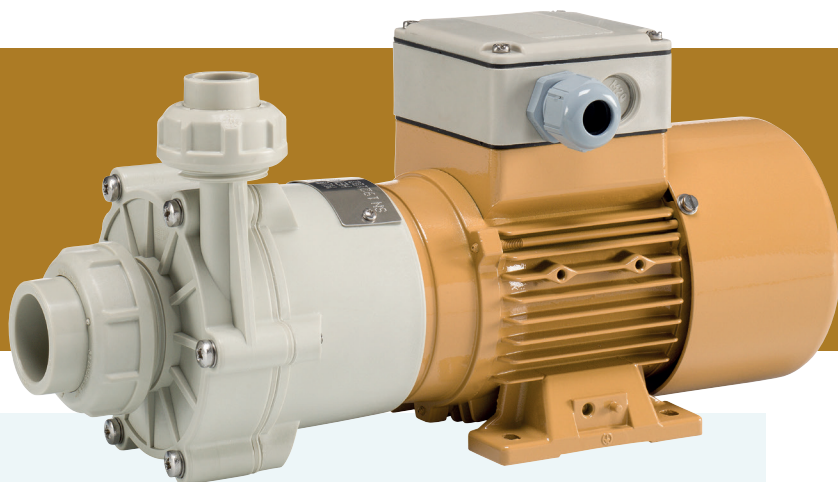

M10-PP

**120 - 4200 l/h**

2 - 70 l/min

Magnetic drive pump, sealless and therefore leak free and safe for people, environment and equipment.

The M10 series combines optimized hydraulic efficiency with a robust, compact and reliable construction. This results in maximum installation uptime and a long service life, providing best in class performance, technically and economically. The M10 series is designed and manufactured for transfer and circulation of chemicals. Easy to build-in and -out, specially for OEM configurations.

### Features

- Magnetic drive
- Sealless, 100% leak free
- Ceramic bearings
- Including complete +GF+ union ends
- EPDM elastomers for PP and FPM for PVDF
- Max. temperature PP 80°C, PVDF 100°C
- Stainless steel fasteners and type shields
- Extra strong neodymium magnets
- Single stage operation
- High quality European, purpose designed electric motor:
  - 3 phase, 50/60 Hz, 2800/3400 rpm, IP55, multi voltage
  - with double layer 2C chemical resistant coating
  - suitable for frequency drive control

### Options

- Hose connections
- Union sockets in PVC or CPVC
- Specific bearings and elastomers
- Priming chamber
- Electric motor options:
  - EMC compatibility
  - PTC thermistor
  - thermal overload incl. switch and lead
  - single phase
  - specific voltages
  - electrical lead (4 m)
  - other RAL colours

Type	Material	Q max (l/h)	H max (m)	Motor		I nom. (A) 400V-50Hz	In (d/DN)	Out (d/DN)	Net weight (kg)	
				kW	HP				PP	PVDF
M10	PP or PVDF	1200	8,5	0,18	1/4	0,55	32/25	20/15	5	5,5
M11		2200	8,5							
M15		4200	8,5							

Selection example: M10-PP

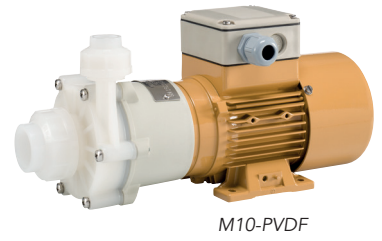
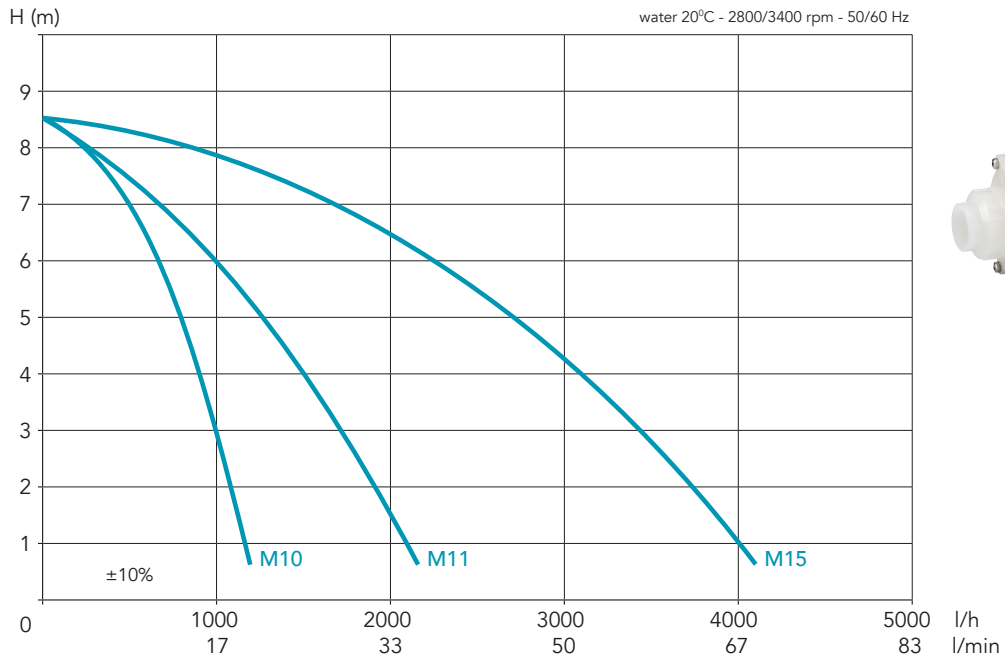

Exploded view

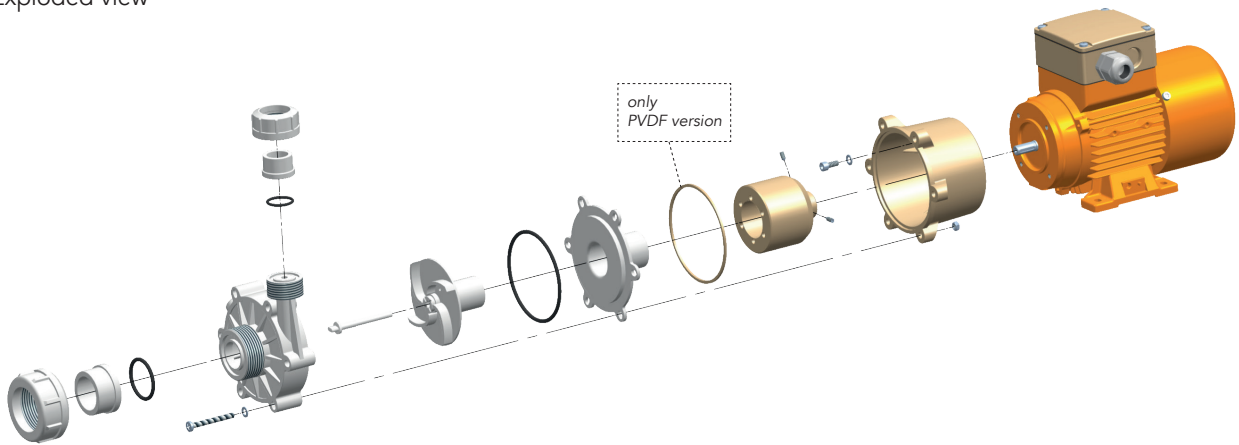

Dimensions

