

HORIZONTAL PUMPS

Magnetic drive

MX160 .. MX410 - PP



MX350-PP

10 - 40 m³/h

167 - 667 l/min

Magnetic drive pump, sealless and therefore leak free and safe for people, environment and equipment.

This MX series combines optimized hydraulic efficiency with a robust, compact and reliable construction. This results in maximum installation uptime and a long service life, providing best in class performance, technically and economically. The MX series is designed and manufactured for transfer and circulation of chemicals. Easy to build-in and -out, specially for OEM configurations.

Features

- Magnetic drive
- Sealless, 100% leak free
- Ceramic/PTFE bearings
- Including complete +GF+ union ends
- EPDM elastomers
- Max. temperature 80°C
- Stainless steel fasteners and type shields
- Extra strong neodymium magnets
- Single stage operation
- High quality European, purpose designed electric motor:
 - 3 phase, 50/60 Hz, 2900/3500 rpm, IP55, multi voltage
 - with double layer 2C chemical resistant coating
 - suitable for frequency drive control

Options

- Hose or flange connections
- Union sockets in PVC or CPVC
- Specific bearings and elastomers
- Dry run protection
- Priming chamber
- Electric motor options:
 - motor mounted frequency drive
 - EMC compatibility
 - PTC thermistor
 - thermal overload incl. switch and lead
 - single phase
 - specific voltages
 - electrical lead (4 m)
 - other RAL colours

Type	Material	Q max (m ³)	H max (m)	Motor		I nom. (A) 400V-50Hz	In (d/DN)	Out (d/DN)	Net weight (kg)
				kW	HP				
MX160	PP	16	16	0,75	1	1,85	40/32	32/25	15
MX210		21	18	1,1	1¼	2,25	40/32	32/25	16
MX260		26	20	1,5	2	2,86	50/40	40/32	22
MX350		35	20	2,2	3	4,13	63/50	50/40	25
MX410		38	22	3	4	5,75	63/50	50/40	35

Selection example: MX260-PP

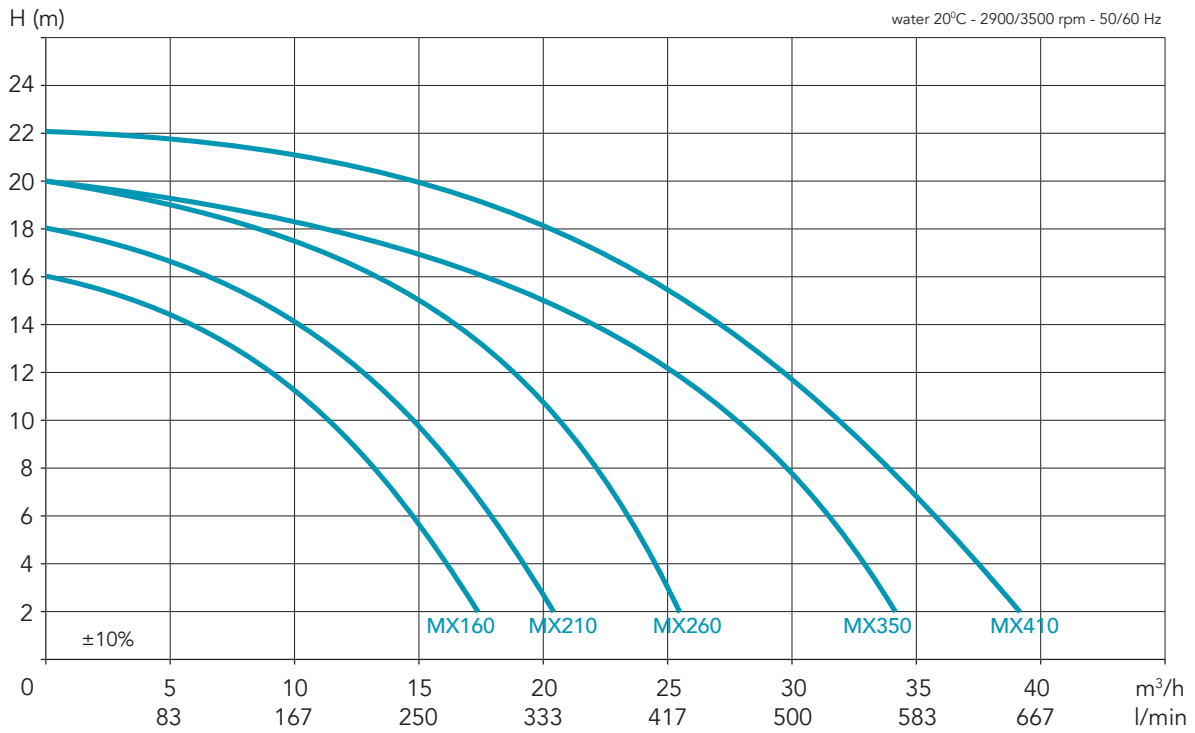

Exploded view

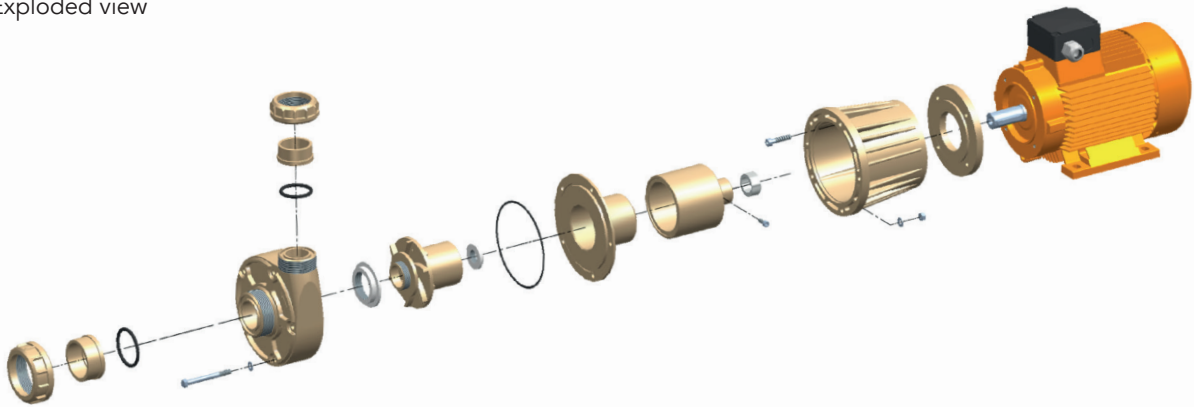

Dimensions

Type	"D"	"l"	"N"	In	Out
MX160	411	205	156	40/32	32/25
MX210	411	205	156	40/32	32/25
MX260	509	236	170	50/40	40/32
MX350	523	253	200	63/50	50/40
MX410	553	254	195	63/50	50/40

