

# SEM210 SEM210X UNIVERSAL TEMPERATURE TRANSMITTER

- **UNIVERSAL INPUT, DUAL CHANNEL**
- **S.I.L APPROVAL, ATEX & IEC Ex Version**
- **MATHS FUNCTIONS**
- **SENSOR CHARACTERISTICS DOWNLOAD VIA USB PORT ALLOWS FOR CUSTOM TYPES**
- **FLASH TESTED TO 4 KV DC**

## ➤ INTRODUCTION

The SEM210 is a universal transmitter that accepts RTD, Thermocouple, Potentiometer or millivolt input signals and converts them to the industry standard (4 to 20) mA transmission signal.

The SEM210 is programmed using a standard USB lead. The ATEX / IECEx version (SEM210X) is programmed with a ATEX / IECEx approved communication lead (USBX Config).

Both versions use our free configuration software USBSpeedlink downloaded from our web site.

## ➤ FEATURE HIGHLIGHTS

### SENSOR REFERENCING

The SEM210 sensor referencing via the Windows based USBSpeedlink software allows for close matching to a known reference sensor eliminating possible sensor errors.

### CUSTOM LINEARISATION

As standard the SEM210 has all common RTD and thermocouple sensors available from its software library. Additionally, the SEM210 can be programmed with up to 22-point custom linearization/ correction where required.

For nonstandard sensors or sensors with unusual or unique characteristics, consult the sales office for details.

### SENSOR BURN OUT DETECTION

If a sensor wire is broken or becomes disconnected the SEM210 output will automatically go to its user defined level (upscale or downscale) or a pre-set value.

### OUTPUT CURRENT PRESET

For ease of system calibration and commissioning the output can be set to a pre-defined level anywhere within the (4 to 20) mA range.

### DIAGNOSTICS

Diagnostic features such as maximum and minimum values stored on the SEM210 are available to view when using the USB configuration software.

A 150-point rate adjustable log is stored on the SEM210 for reviewing of process data.

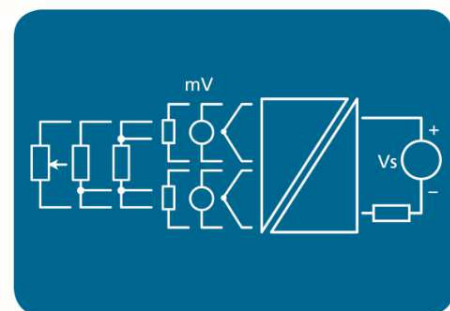

# SEM210 SEM210X UNIVERSAL TEMPERATURE TRANSMITTER

ELECTRICAL INPUT		SPECIFICATIONS @20°C
<b>Range + Options</b>	<b>Accuracy</b>	<b>Stability</b>
<b>Resistance</b>		
(10 to 10000) Ω Excitation 200 μA Lead resistance (0 to 20) Ω (2,3 or 4 Wire connection)	(10 to 500) Ω ± 0.055 Ω, (500 to 2500) Ω ± 0.5 Ω, (2500 to 10500) Ω ± 0.2 % of reading (+ Lead error on 2 wire)	(0 to 500) Ω 0.013 Ω/°C, (500 to 2500) Ω 0.063 Ω/°C, (2500 to 10500) Ω 0.27 Ω/°C
<b>Slide wire</b>		
(0 to 100) % Travel Wire resistance (1 to 100) KΩ	± 0.1 %	±0.001%/°C
<b>mV</b>		
(-205 to 205) mV DC (-1000 to 1000) mV DC	±0.02 mV ±10.0 mV	±0.005 mV/°C ±0.02 mV/°C

SENSOR INPUT		SPECIFICATIONS @20°C
<b>RTD (Single/ 2 wire Dual Channel; isolated tip only for Dual operation)</b>		
<b>Type</b>	<b>Range</b>	<b>Accuracy/ Stability</b>
Pt100 (IEC)	(-200 to 850) °C	0.2°C ± (°0.05% of reading) (Plus sensor error)
Pt500 (IEC)	(-200 to 850) °C	
Pt1000 (IEC)	(-200 to 600) °C	
Ni100	(-60 to 180) °C	
Ni120	(-70 to 180) °C	
Ni1000	(-40 to 150) °C	
Cu53	(-40 to 180) °C	
Cu100	(-80 to 260) °C	
Cu1000	(-80 to 260) °C	
Library contains more (standards/types) Including silicon sensors		
Temperature stability: - Refer to resistance stability values for thermal effect		

SENSOR INPUT		SPECIFICATIONS @20°C
<b>Thermocouple (Single/Dual Channel; isolated tip only for Dual operation)</b>		
<b>Type</b>	<b>Range</b>	<b>Accuracy/ Stability</b>
K	(-150 to 1370) °C	±0.1 % of full scale ± 0.5 °C (Plus sensor error)
J	(-200 to 1200) °C	
N	(-270 to 1300) °C	
E	(-260 to 1000) °C	
T	(-150 to 400) °C	
R	(0 to 1760) °C	±0.1 % of full scale ± 0.5 °C over range (800 to 1760) °C (Plus sensor error)
S	(0 to 1760) °C	
L	(-200 to 900) °C	±0.1 % of full scale ± 0.5 °C (Plus sensor error)
U	(-200 to 600) °C	
B	(0 to 1820) °C	
C	(0 to 2300) °C	
D	(0 to 2300) °C	
G	0 to 2300) °C	
Library contains more (standards/types)		
Temperature stability: - Refer to mV stability values for thermal effect		

# SEM210 SEM210X UNIVERSAL TEMPERATURE TRANSMITTER

COLD JUNCTION (Ambient sensor)		SPECIFICATIONS @20°C
Type	Range	Accuracy/ Stability
Thermistor 10K Beta 3380	(-40 to 85) °C	±0.2 °C
Thermal drift	Zero at 20 °C	±0.05 °C/°C

DUAL CHANNEL OPERATION	
Thermocouples A & B	Functions; Average, Redundancy, A + B, A – B, Highest, Lowest
mV A & B	Functions; Average, A + B, A – B, Highest, Lowest
RTD A & B	Two wire connection. Functions; Average, A + B, A – B, Highest, Lowest

OUTPUT		SPECIFICATIONS @20°C
Type/ Options	Range	Accuracy/ Stability/ Notes
Two wire current	(4 to 20) mA	(mA Out/ 2000) or 5 uA whichever is the greater
Thermal drift	Zero at 20 °C	1 uA/°C
User set minimum current	(3.5 to 4.0) mA 3.8 mA default	
User set maximum current	(20 to 23.0) mA 20.5 mA default	
User set error current	(3.5 to 23.0) mA	
User pre-set current	(20 to 23.0) mA	For diagnostics
Current loop off	3.5 mA	
Loop effect	± 0.2 uA/V	
Loop supply	(10 to 30) V DC, > 35 mA	SELV
Max load	[(V supply – 10)/20] KΩ	700 Ω @ 24 V DC
Protection	Reverse and over voltage	

USER INTERFACE		
Approved USB configuration lead required for SEM210X		
Type/ Options/ Function	Description	Notes
USB 2.0	Mini B USB Approved configuration lead SEM210X	USB powers device for config Only. Power loop for live data.
Baud Rate	38,400	
Sensor Configuration	Sensor type  Sensor offset Sensor fail high or low Pre-set sensor value Set damping Set No. wires, resistance Input Set fixed or auto cold junction	TC/mV/RTD/Ohms/Slide wire Dual TC/mV/RTD Dual sensors use separate offsets Dual sensors share sensor fail For diagnostics  2, 3 or 4 wire
Profiler configuration	Set profiler input range Set profiler segments Enter profile X~Y values Set profiler output units Set the output process range TC & RTD input only set units	In sensor units (4 to 22) segments    Profiler set up

# SEM210 SEM210X UNIVERSAL TEMPERATURE TRANSMITTER

Output signal	Select the process range for re-transmission Set minimum current Set maximum current Set the error current Pre-set Loop current	Set in profiler out units (3.5 to 4.0) mA (20 to 23.0) mA (3.5 to 23.0) mA (3.5 to 23.0) mA
Damping	User set process variable (PV) damping	(1 to 32) seconds to reach 70% final value
Diagnostics	Read (PV, mA, Ambient °C, Error & Power off) logs points back from device Set the log period Clear log and start new log Export log data Detect open circuit sensor wire Calibration date, certificate number, calibrated by	Up to 150 points Log Rate (1 to 60) readings per hour
Live Data	Read process variable (PV) Read profiler input signal Read profiler output signal Read Ambient temperature Read % output Read mA output	

GENERAL	
Function	Description
Isolation	Flash tested 5 Seconds 4 KV DC, working voltage 50 V AC
Reading update	200 ms
Response time	500 ms to reach 70% final value
Warm up	2 minutes
Start-up time	5 seconds

AMBIENT	
Function	Description
Temperature	Operating/Storage (-40 to 85) °C
Humidity	Operating/Storage (10 to 90) %RH non-condensing
Protection	>= IP65
USB configuration ambient	(10 to 30) °C

MECHANICAL	
Enclosure	DIN standard size terminal block
Material	ABS flammability UL94-VO
Dimensions	44 mm diameter 24 mm height
Weight	Approximately 43 g
Fixing centres	33 mm
Centre hole	6.35 mm
Colour	Black SEM210, Blue SEM210X

# SEM210 SEM210X UNIVERSAL TEMPERATURE TRANSMITTER

CONNECTIONS	
Function	Description
Output	Screw terminals (1 to 2)
Input	Screw terminals (3 to 6)
USB	Mini USB for SEM210, approved configuration lead for SEM210X

APPROVALS	
EMC	BS EN 61326 Industrial
Ingress protection	BS EN 60529
RoHS	Directive 2011/65/EU
SIL Accreditation	IEC 61508-2: 2010 clauses 7.4.4 and 7.4.5
ATEX SEM210X	Ex ia IIC T4 Ga
	Ex ia IIIC T135 Da
IECEX SEM210X	Ex ia T4 Ga
	Ex ia IIIC T135 Da

ORDER CODE	
STANDARD	SEM210
ATEX	SEM210X

MECHANICAL: dimensions in mm

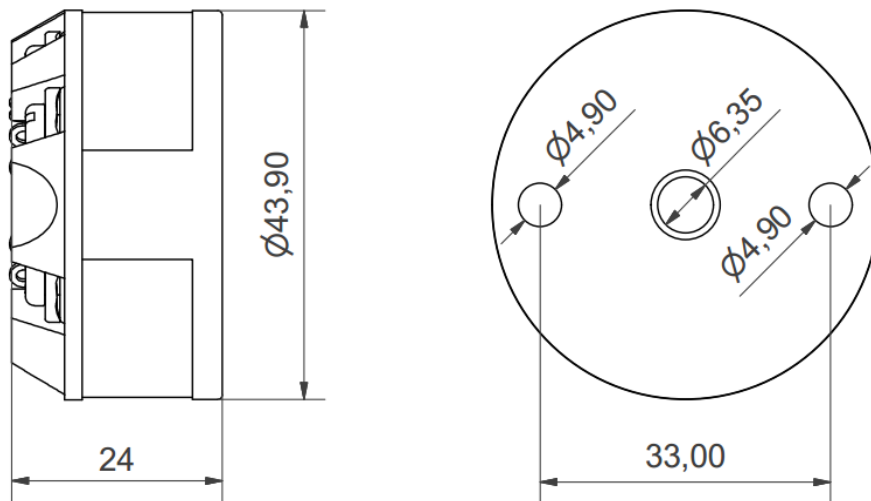

ACCESSORIES	
USB configuration software	USBSpeedLink free of charge from <a href="http://www.status.co.uk">www.status.co.uk</a>
USB programming lead	USB programming lead part number 42-200-0001-01
ATEX programming lead	Refer to <a href="mailto:sales@status.co.uk">sales@status.co.uk</a>
Head enclosure options	Refer to <a href="http://www.status.co.uk">www.status.co.uk</a>
Probe options	Refer to <a href="http://www.status.co.uk">www.status.co.uk</a>

To maintain full accuracy annual calibration is required contact [support@status.co.uk](mailto:support@status.co.uk) for details  
 The data in this document is subject to change. Status Instruments assumes no responsibility for errors