

DUCT HEATERS

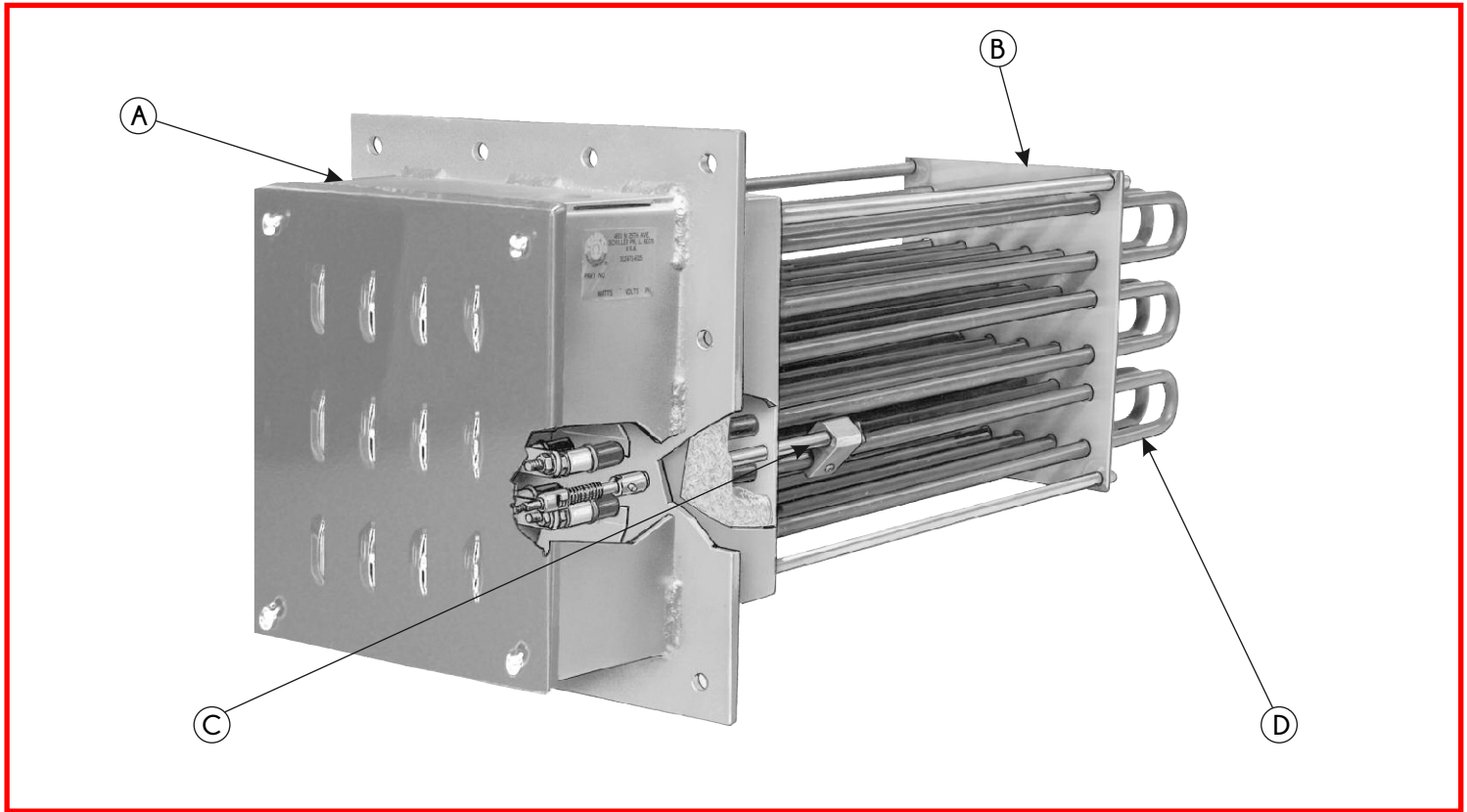

- A** NEMA 1 terminal box enclosure with vented cover to help keep wiring cooler. Optional enclosures : NEMA 4 (moisture resistant).
- B** The heavy duty frame is composed of a 3/16" thick steel mounting flange, stainless steel support plate and corner posts to securely hold the heating elements rigid in any mounting position.
- C** 1/4 inch (6mm) inside diameter thermowell accessed through a 1/8" NPT tapped hole in the flange allows installation of an optional Type J or K thermocouple for sensing the element temperature. For over temperature protection.
- D** Elements are 0.430 inch (11mm) diameter and have Incoloy® sheaths for excellent corrosion resistance and scaling resistance at high temperatures. Element hairpin bends are spanked in special dies to re-compact the MGO refractory to eliminate any electrical voids and hot spots.

Description

- A duct heater which consist of a set of bare tubular heaters or finned tubular heaters mounted in a support made of electplated zinc or stainless steel sheet metal is usually intended to heat air circulating in a duct network.
- Several types of duct heaters can be distinguished according to their applications.

Terminal Air Heater

- Located ahead of the blowing vents in an air-conditioning network. It is relatively low powered (a few kW)
- Circular duct heaters or "drawer type" duct heaters are the most widespread in use.
- "Drawer -type" heaters, which are designed to be installed directly in an opening made in the duct, are built around stored elements.
- They are bent upon request and can be delivered in small series in a week.

Main Air Heater

- Located upstream from the duct network at the air treatment station level.
- It heats the treated air volume in its totality. Its power reaches a few tens of kW.
- Consisting of bare tubular elements or finned tubular elements, these duct heaters generate low transition losses. They are usually built around stored elements, assuring short delivery deadlines, and are installed in a frame made of galvanised steel sheet (stainless on request) sized to the dimensions of the blowing duct.

TUBULAR FINNED DUCT HEATER FOR HORIZONTAL INSTALLATION



To Order : Please specify the complete assembly, indicate the code letter or value for each option.

HEATER	Overall Length	Heater Length	Gulde Plate		Mounting Plate		Cover			
	A _H	B _H	C _H	D _H	E _H	F _H	G _H	H _H	J _H	
DUCT	-	Duct					-			
	-	B _D	C _D	D _D	-	F _D	-	-	-	
	-	-	-	D _H + 1"	-	F _H - 1½"	-	-	-	

FLOW RATE		CFM
INLET TEMP		°C
OUTLET TEMP		°C
INLET RH		% RH
OUTLET RH		% RH
POWER		WATTS
SUPPLY		VAC
PHASE	1 / 3	P
CONNECTION	DELTA / WYE	
NO. of ELEMENTS		

