

## INFRARED QUARTZ HEATERS

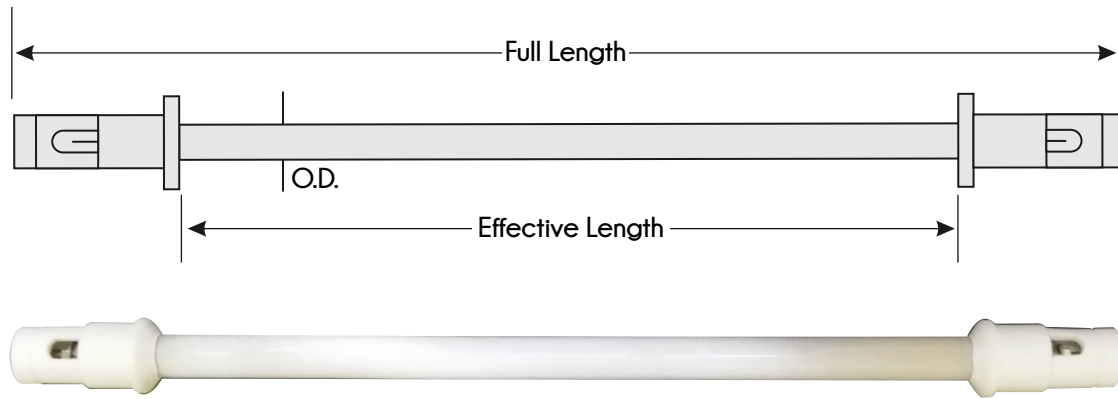

Straight long wave infrared rays can be easily arranged to fall on an object by use of a reflection plate. If the cross-section of the reflection plate is the cross-section of the reflection plate is designed in parabolic shape, most of the reflected rays will go in parallel direction to heat the object. Aluminum plate has excellent reflective power. Stainless plate is slightly inferior to aluminum plate while stainless plate must be used where corrosive gas emerges. There is a 30% difference between the use of parabolic reflection plate and a plane type. Therefore a parabolic reflection plate should be used whenever it is possible. For maintaining the efficiency of the reflector cleaning must be done.

### Typical Applications

- Food warming
- Thawing
- Skin packaging tunnels
- Drying lacquers and paints
- Thermal copying element
- Food processing
- Water dry off
- Sterilization
- Print curing and drying

### Product Specifications

Effective Length (mm)	Full Length (mm)	O.D. Ø	Voltage (V)	Wattage (W)
250	375	14	110	300
300	425	14	110	450
350	475	14	110	500
400	525	14	220	450
400	525	14	220	600
450	575	14	220	500
450	575	14	220	650
500	625	14	220	550
500	625	14	220	750
550	675	14	220	600
550	675	14	220	800
600	725	14	220	6650
600	725	14	220	850
700	825	14	220	750
700	825	14	220	1KW
750	875	14	220	800
750	875	14	220	1.1KW
800	925	14	220	900
800	925	14	220	1200

Effective Length (mm)	Full Length (mm)	O.D. Ø	Voltage (V)	Wattage (W)
300	425	17	110	550
400	525	17	110	700
500	625	17	220	650
500	625	17	220	850
600	725	17	220	800
600	725	17	220	1KW
750	875	17	220	1KW
750	875	17	220	1300
800	925	17	220	1100
800	925	17	220	1400
900	1025	17	220	1200
900	1025	17	220	1500
1000	1125	17	220	1300
1000	1125	17	220	1700
1200	1325	17	220	1600
1200	1325	17	220	2000
1300	1425	17	220	2000
1400	1525	17	220	2100
1500	1625	17	220	2300
1600	1725	17	220	2400

### Focus type reflector

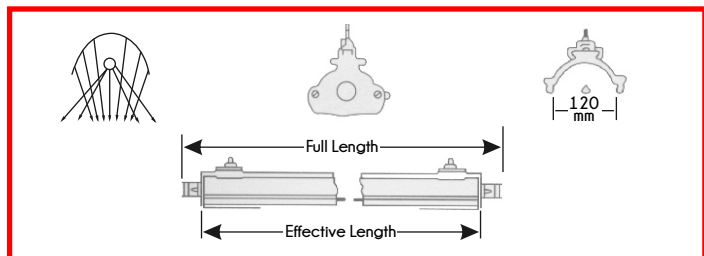

### Ceramic protector and cap

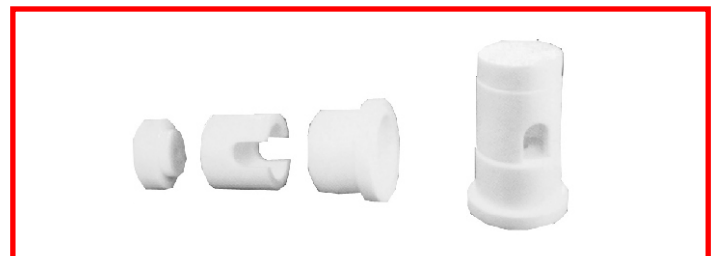

# QUARTZ INFRAPARA HEATER



To Order : Please specify the complete assembly, indicate the code letter or value for each option.

Model	Length - L <sub>H</sub>	Diameter - Ø <sub>H</sub>	Wattage	Supply
HE - QI				

14	Ø14mm
17	Ø17mm

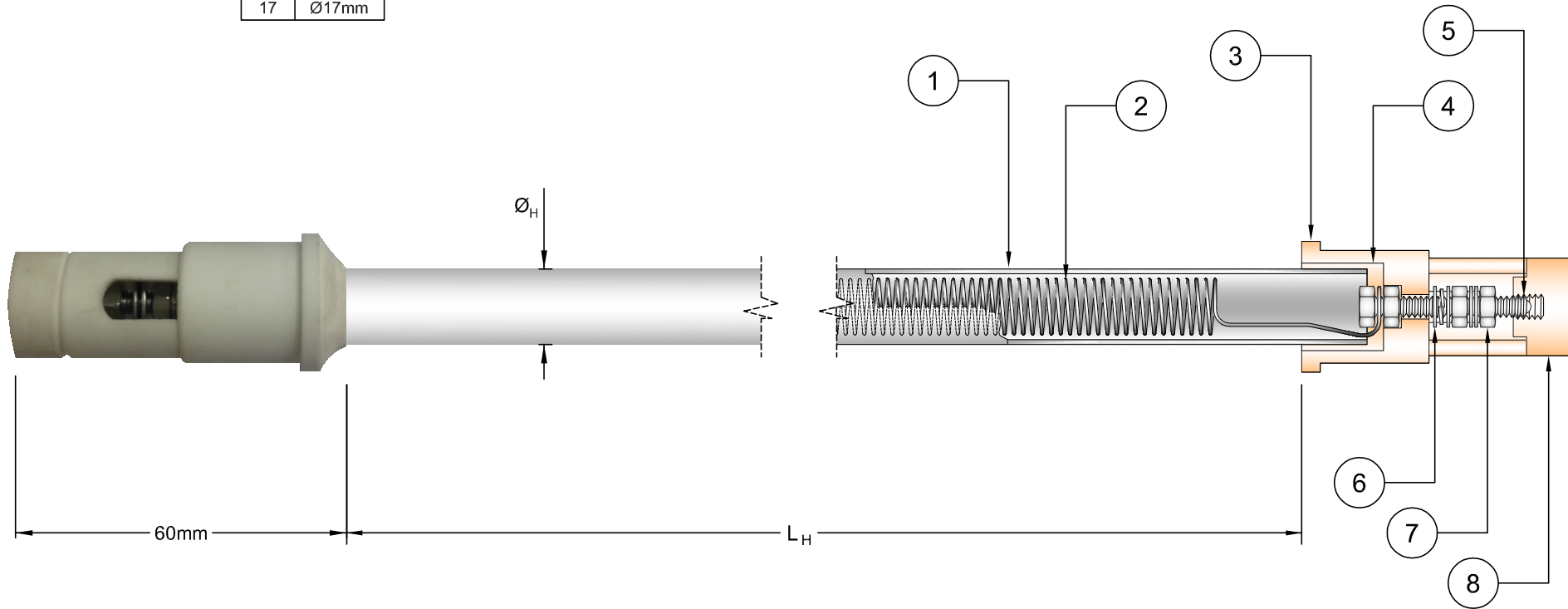

	Description
1	Quartz Tube
2	Nichrome Wire
3	Ceramics
4	Cement
5	Stainless Steel Bolt M4
6	Washer
7	Nut
8	Wire Insulator and Cap