

# 3HX Series

## PRODUCT DATA SHEET

### Fluoropolymer Heater

**Excellent chemical resistance to aggressive acids!**

Inert to most solutions

Low Watt density design saves space & ensures long life

Corrosion-resistant head

Built-in thermal protector & grounded element

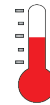

Up to 100°C (212°F)



1,000 to 6,000 watts



120 to 600 Volts



PTFE sleeved 304 stainless steel



cULus  
CE (except 600 Volts)

3HX SERIES, THREE ELEMENT FLUOROPOLYMER (PTFE) HEATERS						
WATTS	VOLTS	HOT ZONE in/(mm)	OVERALL LENGTH in/(mm)	MODEL NUMBER	SHIP WGT. lbs/(kg)	
1000	120	10	17	3HX1117-1**	10	
	240	(254)	(432)	3HX1217-**	(4.5)	
1500	120	16	23	3HX1.5123-1**	11	
	240	(406)	(584)	3HX1.5223-**	(5)	
	480			3HX1.5423-**		
2000	120	22	29	3HX2129-1**	12	
	240	(559)	(737)	3HX2229-**	(5.4)	
	480			3HX2429-**		
3000	240	29	35	3HX3235-**	14	
	480	(737)	(889)	3HX3435-**	(6.4)	
4000	240	39	47	3HX4247-**	17	
	480	(991)	(1194)	3HX4447-**	(7.7)	
5000	240	48	59	3HX5259-**	20	
	480	(1219)	(1499)	3HX5459-**	(9.1)	
6000	240	56	68	3HX6268-**	23	
	480	(1422)	(1727)	3HX6468-**	(10.4)	

Three-phase standard

**PROCESS  
TECHNOLOGY**

ISO 9001:2015  
WITH DESIGN CERTIFIED

## Features & Values

- Inert to most aqueous acid, alkaline, anodizing, & pickling solutions up to 100°C (212°F)
- Rugged, heavy wall PTFE covered stainless steel element reduces permeation. Guaranteed 100% pinhole free
- Space saving & long service life with low Watt density design of 10 W/in<sup>2</sup> (1.5 W/cm<sup>2</sup>)
- Vapor-resistant, flame retardant polypropylene terminal enclosure with 3 ft (.9m) flexible PVC liquid tight conduit
- Lower Watt densities available for highly viscous solutions & technical acids

## Specifications

**Wattages** 1,000 to 6,000 Watts

**Voltages** 120 to 600 Volts

**Temperature Range** Up to 100°C (212°F)

- Safety Features**
- Grounded internal metal element
  - Built-in thermal protector. Replaceable P1 protector standard for up to 82°C (180°F). Other options available
  - Non-floating construction

**Certifications** cULus listed  
CE compliant (except 600V)

## Dimensions

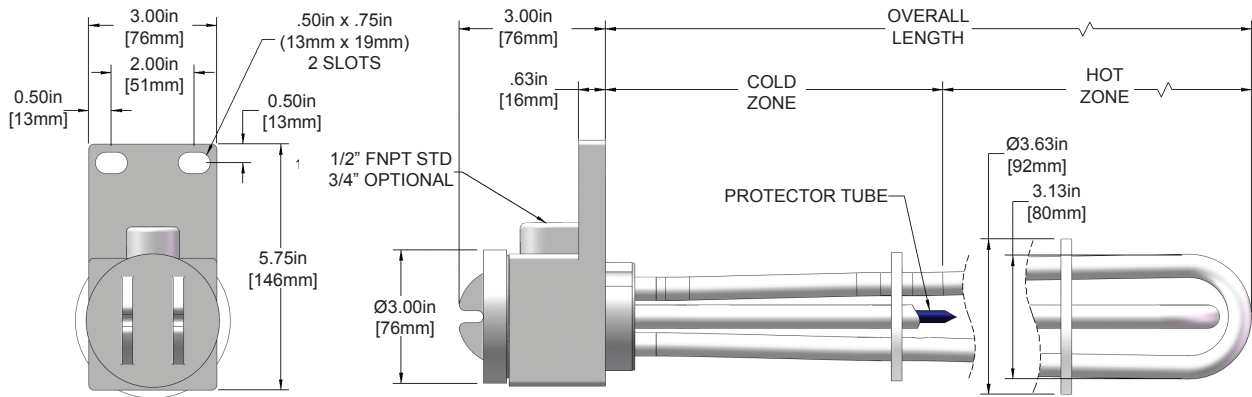

## Model Number Breakdown

Series	Wattage	Voltage	Overall Length	Phase	Type of Protector	Wire & Conduit Length
3HX = PTFE	1 = 1000	1 = 120	17 = 1kW	1 = single	<b>Replaceable Fuse</b>	36" length standard (no designator)
	1.5 = 1500	2 = 240	23 = 1.5kW		P1 (std) = solutions up to 190°F	Specify variations from standard Ex: -X84 = 84"
	2 = 2000	3 = 380	29 = 2kW		<b>Resettable Fuse</b>	
	3 = 3000	4 = 480	35 = 3kW		P2 = solutions up to 190°F	
	4 = 4000	5 = 415	47 = 4kW		P8 = solutions up to 210°F	
	5 = 5000	6 = 600	59 = 5kW		P3 = solutions up to 250°F	
	6 = 6000	7 = 400	68 = 6kW			
		8 = 208				
		9 = 220				
		0 = 200				

**PROCESS  
TECHNOLOGY**