

# 8-CHANNEL SCANNER

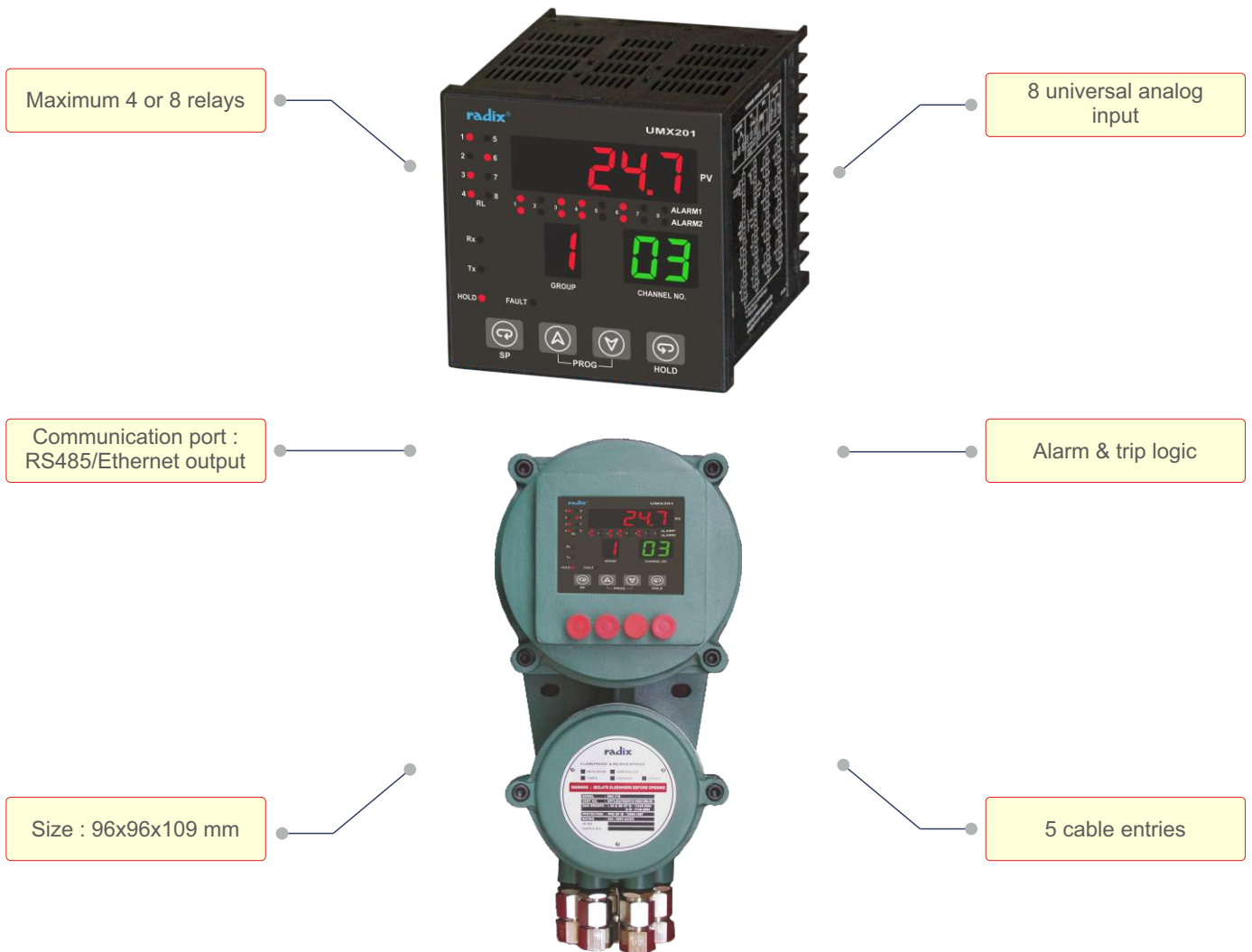

- 8 universal analog inputs
- 8 thermocouples, Pt50, Pt100, Cu53, 0~100 mV, 0~5 V, 0~10 V, 1~5 V, 0/4~20 mA
- Isolated RS485/MODBUS RTU, Upto 57600 Baud or MODBUS/TCP & Telnet multidrop communication for PLC, SCADA, etc.
- 85~265 VAC or 18~35 V DC supply
- 4 key, 6 level programming
- Maximum 4 or 8 relay outputs
- Powerful, flexible SCADA software available

# 8-CHANNEL SCANNER

## SPECIFICATIONS

All specifications at ambient of 25 °C, unless specified otherwise

<b>INPUTS</b> Maximum no. of channels Input types Thermocouple RTD Linear input  Channel scan rate Range limits Accuracy  Warmup time for specified accuracy Cold junction compensation Sensor break protection		8  B, E, J, K, N, R, S, T Pt100, 3-wire, Pt50, Cu53 0~100 mV, 0~5 V, 0~10 V, 1~5 V, 0~20 mA, 4~20 mA (0~5 V, 0~10 V, 1~5 V input requires DIP reconfiguration. Rest of the inputs are independently scalable without any DIP reconfiguration. For DC current output, 47 ohms (0.1%, 50 ppm) shunt resistor must be connected externally) < 3 seconds for 8 channels See Table 1 Thermocouple : ±0.25% of FS ±1°C Pt100 : ±0.05% of FS ±1°C Linear inputs : ±0.25% of FS ±1 digit 30 min  Automatic User programmable
<b>OUTPUTS</b> No. of relays Relay contact type Relay contact rating SSR drive signal		See Table 2 See Table 2 3A / 250V AC, resistive 12 V DC for external SSR
<b>INDICATION</b> Process variable  Channel no.  Group no.  Status indication		5 digit, 7-segment 0.56" (14.2 mm), red LED display module 2 digit, 7-segment 0.56" (14.2 mm), green LED display 1 digit, 7-segment 0.56" (14.2 mm), red LED display 8 LEDs for alarm1 8 LEDs for alarm2 4 LEDs for relay 1 LED for hold 2 LEDs for Rx & Tx 1 LED for fault
<b>COMMUNICATION</b> <b>RS485</b> Port Protocol Baud rate Slave ID Minimum polling interval Data types Parity  <b>ETHERNET</b> System CPU Communication interface Ethernet Protocol  COM port format Data bit Parity Stop bit Baud rate  Slave ID Minimum polling interval Data types		RS485, isolated MODBUS RTU 4800/9600/19200/38400/57600 bps User programmable, 1~247 250 milliseconds Integer, integer x10 None, Odd, Even  32 bit MCU  10/100 base TX , RJ-45 Modbus/TCP & Telnet  8 None 1 9600 bps User programmable, 1~247 250 milliseconds Integer, integer x10
<b>POWER SUPPLY</b> Supply voltage		a. 85~265V AC, 50/60hz b. 18~35 V DC
<b>ISOLATION</b> Mutual isolation between input, supply, relays, analog output, digital input, RS485		1500 VAC RMS, 50hz / 1 minute
<b>ENCLOSURE</b>		See Table 2
<b>TEMPERATURE, HUMIDITY</b> Ambient, storage Ambient, operation Relative humidity		-22~+85°C 0~50°C 0~95%
<b>OTHER</b> Keypad Memory for programmed parameters Power consumption		Tactile, 4 keys Non-volatile, indefinite duration  4 watts
<b>PROGRAMMABLE PARAMETERS</b> Setpoint Alarm Unit Resolution  Display scan rate SKIP channel Input bias Alarm functions  Control action Hysteresis Alarm type		Full range (see Table1) Full range adjustable User selectable User selectable 0.0001,0.001,0.01, 0.1 or 1 for linear input, 0.1 or 1 for temperature 1~99 seconds/channel Enable/disable -99.9 ~ 99.9 High Low High-Very High Very Low-Low Low-High Direct / reverse 0.01 ~ 9.99 Selfreset, Latch, Hold, Latch + Hold Once relay gets ON, it remains 'ON' until alarm is acknowledged by  key Alarm is disabled at power ON. After process variable reaches normal (non alarm) value, the alarm is enabled Combination of Latch & Hold logic 0~999 seconds 5~240 seconds
Alarm type		Latch (Ltch)  Hold  Ltch.Hold
Alarm activation delay Power on activation delay		0~999 seconds 5~240 seconds

# 8-CHANNEL SCANNER

**TABLE 1**

SENSOR / INPUT	RANGE LIMITS (°C / EU)	
	LOW SCALE	HIGH SCALE
Pt - 6% Rh / Pt - 30% Rh (B)	400	1800
Chromel / Constantan (E)	-200	850
Iron / Constantan (J)	-200	760
Chromel / Alumel (K)	-200	1370
Nicrosil / Nisil (N)	-200	1300
Pt / Pt - 13% Rh (R)	0	1700
Pt / Pt - 10% Rh (S)	0	1700
Copper / Constantan (T)	-270	400
Pt100, 3-wire	-200	850
Cu53	0	150
Linear (0~100mV, 0~5 V, 0~10 V, 1~5 V, 0~20 mA, 4~20 mA)	-19999	19999

## RELAY ASSIGNMENT

### RELAY GROUP TYPE 2

For 4 relay output = Maximum group 2 (G-1, G-2)  
For 8 relay output = Maximum group 4 (G-1, G-2, G-3, G-4)

Each group has two relay.

G-1 : Relay1 & Relay2      G-3 : Relay5 & Relay6  
G-2 : Relay3 & Relay4      G-4 : Relay7 & Relay8

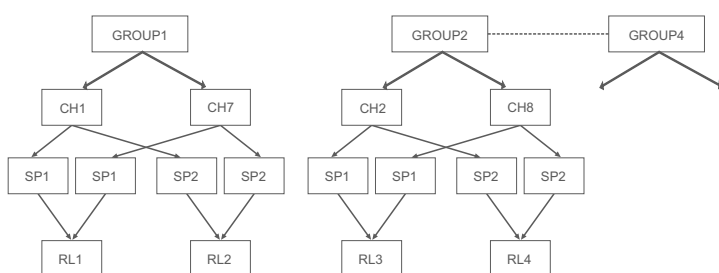

#### Example

Channel No.	Group selected	Setpoint selected	Relay No.
1	G-1	SP1 & SP2	1 & 2
2	None	-	-
3	G-2	SP1 & SP2	3 & 4
4	G-3	SP1 & SP2	5 & 6
5	G-2	SP1 & SP2	3 & 4
6	G-4	SP1 & SP2	7 & 8
7	None	-	-
8	G-2	SP1 & SP2	3 & 4

Note : 1) Both groups can not be selected for single channel  
2) None means no group & setpoint is selected for particular channel

### RELAY GROUP TYPE 4

For 4 relay output = Maximum group 4 (G-1, G-2, G-3, G-4)  
For 8 relay output = Maximum group 8 (G-1, G-2, G-3, G-4,  
G-5, G-6, G-7, G-8)

Each group has one relay .

G-1 : Relay1      G-2 : Relay2      G-3 : Relay3      G-4 : Relay4  
G-5 : Relay5      G-6 : Relay6      G-7 : Relay7      G-8 : Relay8

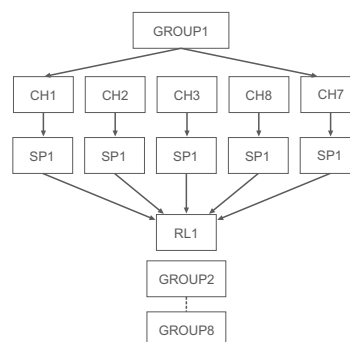

#### Example

Channel No.	Group selected	Setpoint selected	Relay No.
1	G-1	SP1	1
2	G-2	SP1	2
3	G-3	SP1	3
4	None	-	-
5	G-4	SP1	4
6	G-5	SP1	5
7	G-7	SP1	7
8	G-8	SP1	8

Note : 1) More than 1 group can not be selected for single channel  
2) None means no group is selected for particular channel

# 8-CHANNEL SCANNER

## DIMENSIONS mm

Fig 1 : PANEL MOUNT

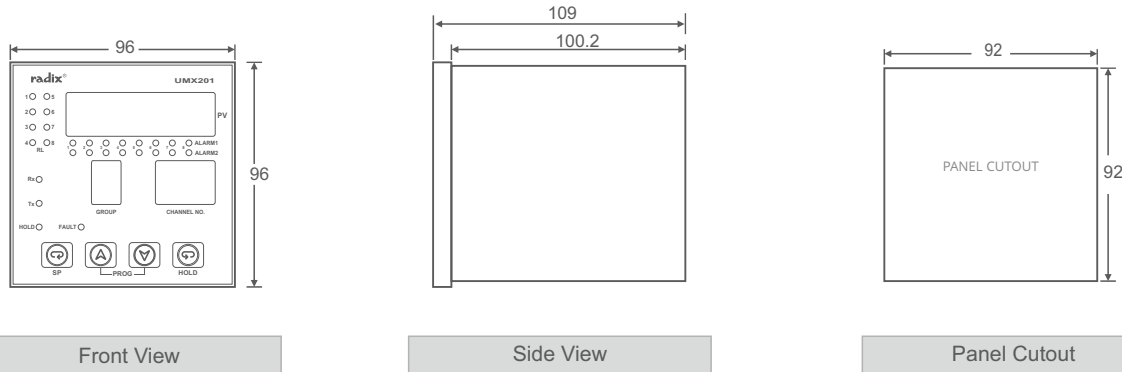
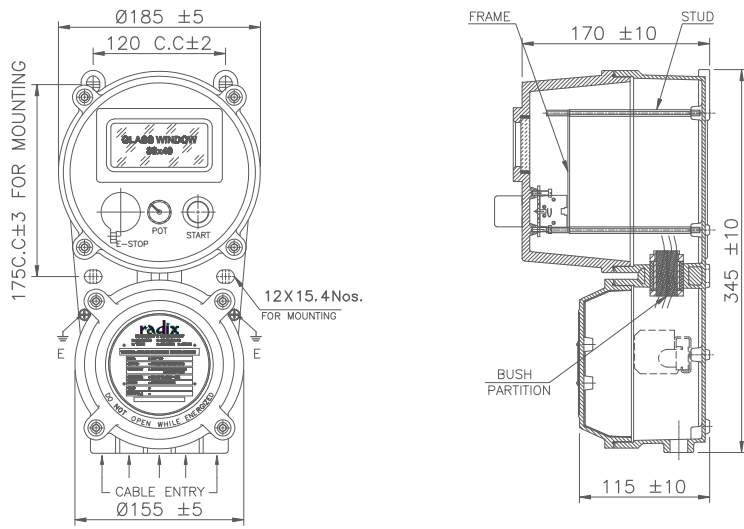

Fig 2 : WALL MOUNT FLAMEPROOF





# 8-CHANNEL SCANNER

## CONNECTIONS

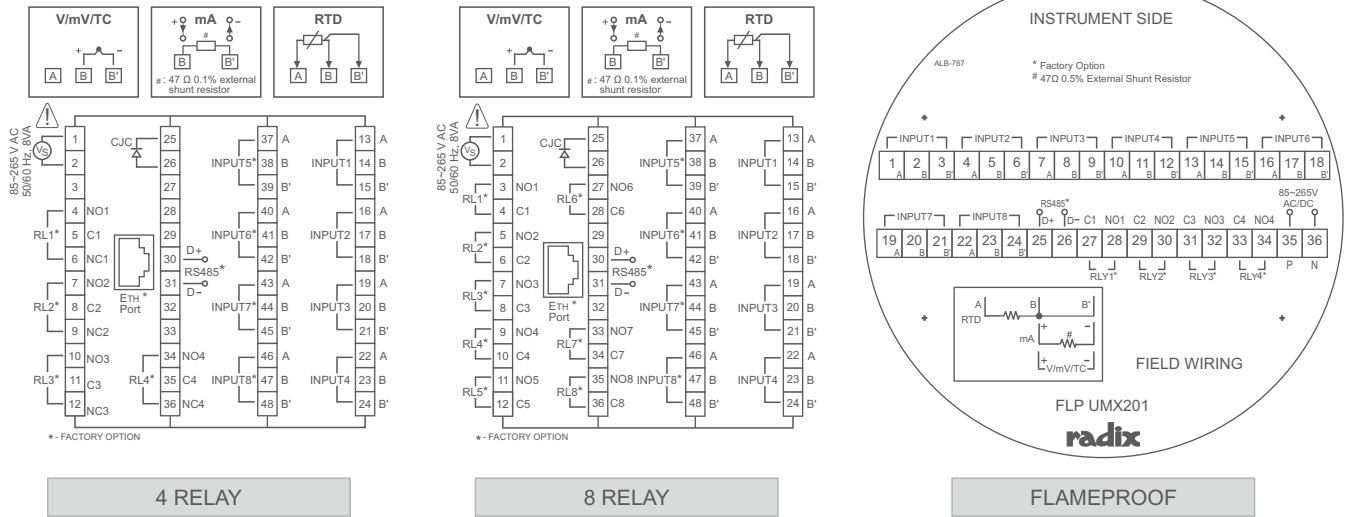
Fig 3



## TABLE 2

Product Photo		
Model	UMX201 - Panel Mount	FLP UMX201 - Wall Mount Flameproof
No. of Inputs/Input Type	Eight universal inputs TC : B, E, J, K, N, R, S, T RTD : Pt100, Pt50, Cu53 Linear : 0~100mV, 0~5V, 0~10V, 1~5V, 0~20mA, 4~20mA	Eight universal inputs TC : B, E, J, K, N, R, S, T RTD : Pt100, Pt50, Cu53 Linear : 0~100mV, 0~5V, 0~10V, 1~5V, 0~20mA, 4~20mA
Dimensions (in mm)	96(W) x 96(H) x 109(D) See Fig1	352(H) x 190(W) x 170(D) See Fig2
Enclosure Construction	Plug-in (circuit removable without affecting terminal wiring)	-
Relay Outputs	4 relays (NO-C-NC) / 8 relays (NO-C)	4 relays (NO-C)
Communication	RS485/MODBUS/RTU, isolated, multiple programmable Baud rate or MODBUS / TCP & Telnet multidrop communication	RS485/MODBUS/RTU, isolated, multiple programmable Baud rate
Mounting	Panel	Wall
Panel cutout	92x92 mm	-
Terminals	M3 screw, suitable upto 2 mm <sup>2</sup> wire	M2.5 screw, suitable upto 2.5 mm <sup>2</sup> wire
Housing Material	ABS plastic	Cast AL (Powder coated)
Protection	-	IP65
Certification	-	Flameproof, Gr IIA, IIB & IIC
Cable Gland	-	5 x 3/4" ET
Weight	515.5 g	Approx. 4 kg
Maximum Configuration	A) 8 x Inputs, 8 x Relays (NO-C), RS485 B) 8 x Inputs, 4 x Relays (NO-C-NC), RS485	8 x Inputs, 4 x Relays (NO-C), RS485

# cable gland to be ordered separately

# 8-CHANNEL SCANNER

## ORDERING INFORMATION

Model : UMX201 - Panel Mount

Example	2843	0	1	0	1	0	2843 0 1 0 1 0
Product Code	2843						
No. of Channels		0					4 channels
		1					8 channels
No. of Relays			0				None (indicator)
			1				4 relays
			2				8 relays
Input Types				0			Universal
				1			All channels are Pt100
				2			All channels are 4 ~ 20mA
				3			All channels are T/C K
				4			Others
Communication					0		Not provided
					1		RS485, isolated
					2		Ethernet port (MODBUS/TCP)
Supply Voltage						0	85~265 VAC
						1	18~35 VDC

EXAMPLE

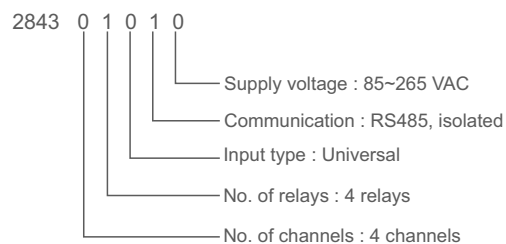

Model : FLP UMX201 - Wall Mount Flameproof

Example	2844	0	1	0	1	0	2844 1 0 0
Product Code	2844						
No. of Channels		0					4 channels
		1					8 channels
No. of Relays			0				None (indicator)
			1				4 relays
Input Types				0			Universal
				1			All channels are Pt100
				2			All channels are 4 ~ 20mA
				3			All channels are T/C K
				4			Others
Communication					0		Not provided
					1		RS485, isolated
Supply Voltage						0	85~265 VAC
						1	18~35 VDC

EXAMPLE

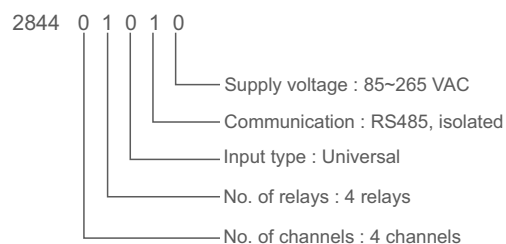

## PREFERRED ORDER CODE

SR NO	PRODUCT	ORDER CODE	BRIF SPECIFICATION	POWER SUPPLY
1	UMX201	2843 10000	Inputs : 8	SMPS
2	UMX201	2843 10010	Inputs : 8, MODBUS	SMPS
3	UMX201	2843 11000	Grouping/Common alarms, Inputs : 8, Outputs : 4	SMPS
4	UMX201	2843 11010	Grouping/Common alarms, Inputs : 8, Outputs : 4, MODBUS	SMPS
5	UMX201	2843 12000	Grouping/Common alarms, Inputs : 8, Outputs : 8	SMPS
6	UMX201	2843 12010	Grouping/Common alarms, Inputs : 8, Outputs : 8,MODBUS	SMPS
7	FLP UMX201	2844 10000	Inputs : 8, Flameproof	SMPS
8	FLP UMX201	2844 10010	Inputs : 8, MODBUS, Flameproof	SMPS
9	FLP UMX201	2844 11000	Inputs : 8, Outputs : 4, Flameproof	SMPS
10	FLP UMX201	2844 11010	Inputs : 8, Outputs : 4, MODBUS, Flameproof	SMPS

CAT#561R3/A