



PMD330

Differential Pressure Transmitter(Indoor)

Pressure-PMD330



| Features |

- Silicon chips on differential pressure module of MEMS integration technology
- Offset function / UI software
- Low-pressure monitoring, high pressure resistance
- RS-485 communication interface (Optional), Modbus RTU protocol
- Physical unit switch (User Interface) : mbar / Pa / hPa / kPa / mmH₂O / mmWS / inH₂O / mmHg
- Square root function

| Applications |

Monitor differential pressure of cleanroom / Hospital / Air duct / Filter environment and monitor air flow

| Specification |

Input

Input type	Piezoelectric differential pressure module
Measuring range	$\pm 50 \dots \pm 10000 \text{ pa}$

Output

Output	4 ... 20 mA / 0 ... 10 V
Signal connection	3-wire
Modbus	RS-485
Load resistance (Current output)	4 ... 20 mA < 500 Ω 0 ... 10 V $\geq 1 \text{ K}\Omega$
Response time(t63)	$\leq 2 \text{ ms}$
Display type	LCD module with back light, double line character
Display range	Upon request, 2 decimal place (as unit is Pa : 1 decimal place)
Digit height	5.56 mm

Environment

Measuring medium	Air
Operating temperature	0 ... 50°C
Operating humidity	0 ... 95%(Non-condensing)
Storage temperature	-20 ... +60°C

Accuracy (at 25°C)

Accuracy	$\pm 2.0\%$ of F.S.
Temperature influence	$\pm 1.75\%$ (5 ... 55°C)

Electrical

Power supply	AC 24 V $\pm 10\%$ / DC 24 V $\pm 10\%$
Current consumption	DC 24 V : $\leq 45 \text{ mA}$ (Display) / $\leq 40 \text{ mA}$ (Non-display) AC 24 V : $\leq 95 \text{ mA}$ (Display) / $\leq 90 \text{ mA}$ (Non-display)
Overvoltage protection	$\leq \text{DC } 40 \text{ V}$
Electrical connection	M12 connector / M16 terminal

Installation

Installation	Indoor
--------------	--------

Protection

IP rating	IP65
Electrical protection	■ Polarity protection ■ Over-voltage ■ Short circuit
Pressure resistance	$\pm 50 \dots \pm 500 \text{ pa}$: 0.25 bar $\pm 1000 \dots \pm 10000 \text{ pa}$: 0.5 bar
Burst pressure	$\pm 50 \dots \pm 2500 \text{ pa}$: 0.75 bar $\pm 5000 \dots \pm 10000 \text{ pa}$: 1.25 bar

Certification

Certification	CE
---------------	----

Material

Housing	PC fire-proof class(PC-110)(UL94V-2)
Weight	Display : 152g ; Non-display : 127g

*Please make sure the product and the device which connect with RS-485 are on common ground, avoid damaged product.

| Pressure Unit Conversion Table |

Unit	Pa	mbar	hPa	kPa	mmWS	inH ₂ O	mmHg
Range	$\pm 50 / 100$	0.5 / 1	0.5 / 1	0.05 / 0.1	5 / 10	0.2 / 0.4	0.375 / 0.75
	$\pm 300 / 500$	3 / 5	3 / 5	0.3 / 0.5	30 / 50	1.2 / 2	2.25 / 3.75
	$\pm 1000 / 1600 / 2500$	10 / 16 / 25	10 / 16 / 25	1 / 1.6 / 2.5	100 / 160 / 250	4 / 6.4 / 10	7.5 / 12 / 18.75
	$\pm 5000 / 7500 / 10000$	50 / 75 / 100	50 / 75 / 100	5 / 7.5 / 10	500 / 750 / 1000	20 / 30 / 40	37.5 / 56.25 / 75

| Dimension |

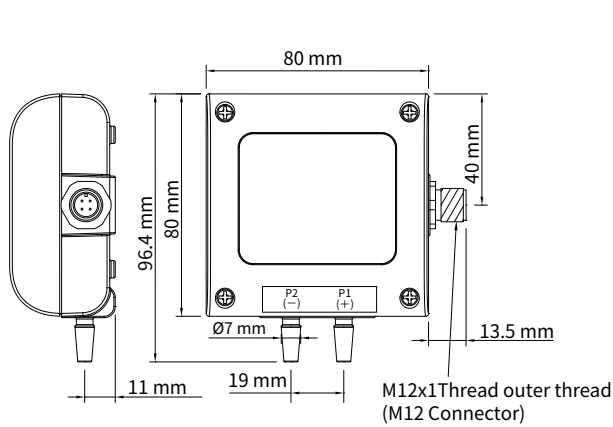

Indoor — M type

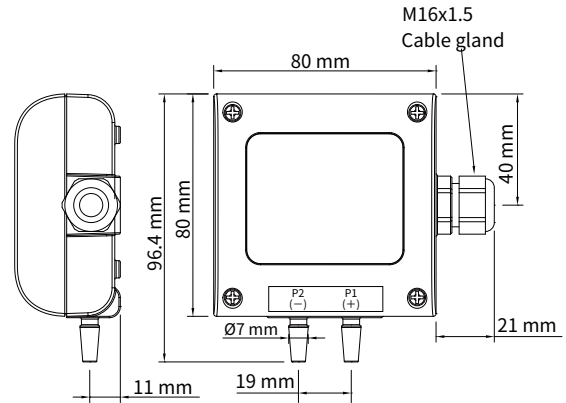

Indoor — N type

| Connection Diagram |

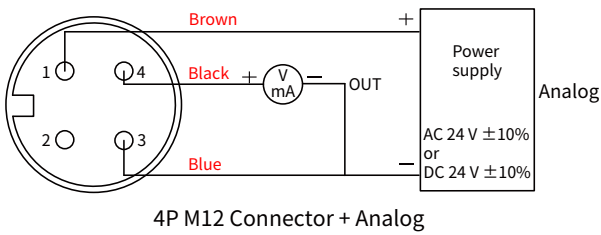

4P M12 Connector + Analog

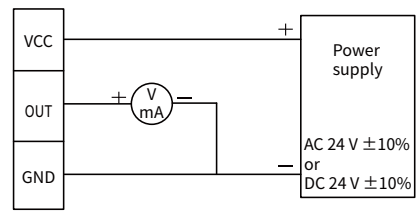

3P Terminal, analog

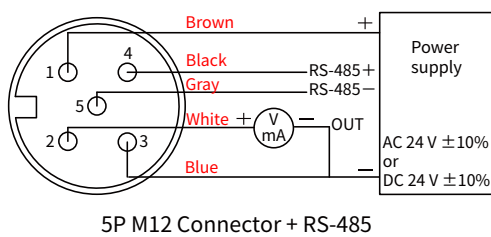

5P M12 Connector + RS-485

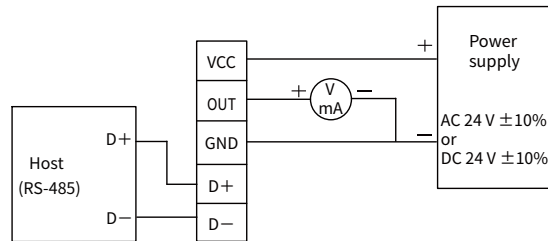

5P Terminal, analog + RS-485

| Ordering Guide |

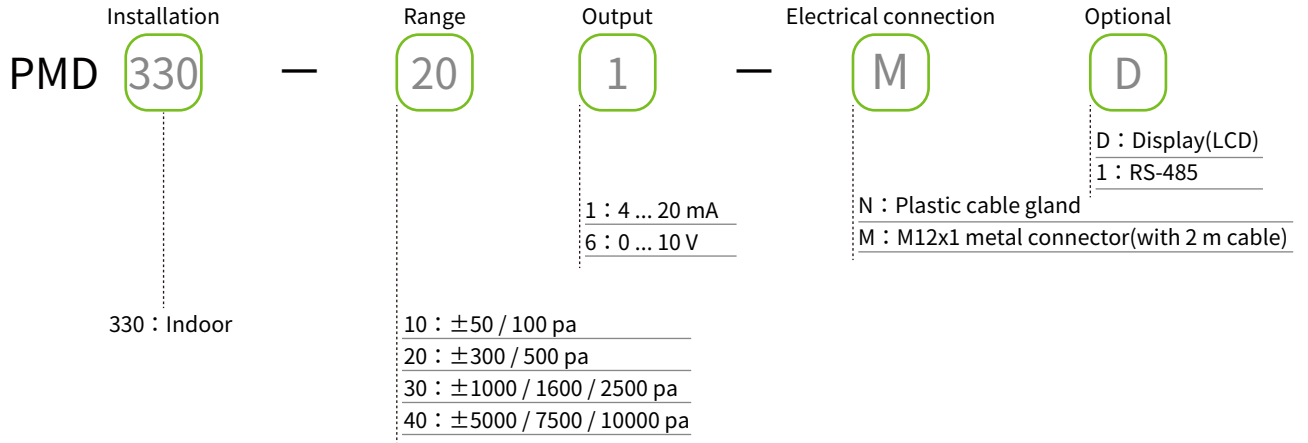

| Additional Option Test Report | For more detailed information please contact us.

■ ISO 9001

Project	Measurand level or range
Pressure	Differential pressure : 0 ... 500 Pa / 0 ... 1000 Pa / 0 ... 10000 Pa