

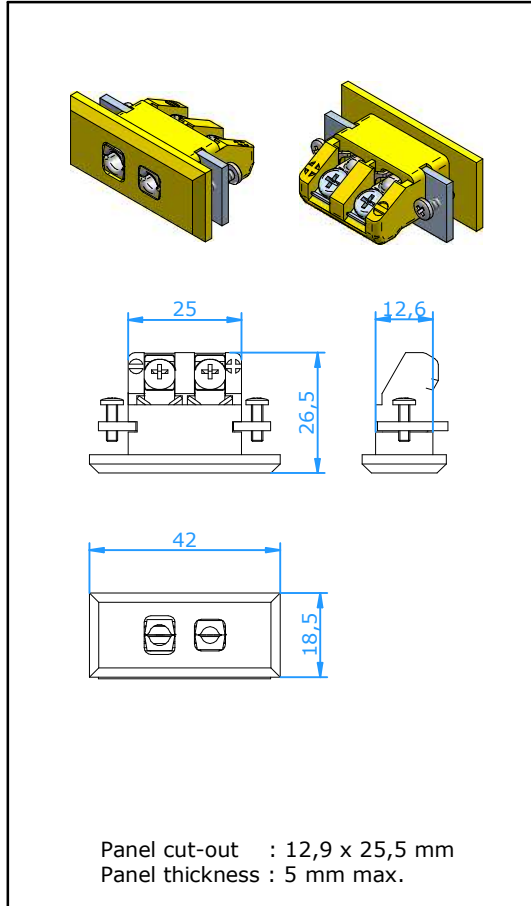

Panels

Panel Standard Insert Flanged Bracket Mounting



Application

Panel insert for thermocouple and RTD circuits. Mounting by means of a stainless steel bracket and two screws.

Construction

- Glass filled thermoplastic body with original thermocouple material pins and springloaded inserts.
- Polarized pins ensure proper connection.
- Molded barriers prevent short circuit.
- Polarity indication on the body
- Rugged one body design.
- Stainless steel screws and bracket for rear mounting

Wire size

- Accepts wires up to 1,6 mm.

Temperature Rating

- 220 °C Max.

Color Code:

- Available in all color code standards, incl. NFE, BS, JIS, etc.

Ordering Code : **PSIFB-xx**

For last two digits 'xx' see table below

| | | | | | | | | | |
|---|--------------|------------|--------------|----------------|------------|-----------|-----------------|----------------|------------------|
| Calibration Code | E | J | K | N | T | U | R/S | C | B |
| Compensation material for Material Positive | | | | | | | Pt13Rh/ Pt | W5Re/ W26Re | Pt6Rh/ Pt30Rh |
| Material Negative | NiCr CuNi | Fe CuNi | NiCr NiAl | NiCrSi NiSi | Cu CuNi | Cu Cu | Cu Alloy #11 | CPX CNX | Cu Cu |
| IEC Color Code | | | | | | | | | |
| Color Body | Violet | Black | Green | Pink | Brown | White | Orange | Red | Grey |
| Code | EI | JI | KI | NI | TI | UI | RI | C | BI |
| ANSI Color Code | | | | | | | | | |
| Color Body | Violet | Black | Yellow | Orange | Blue | White | Green | Red | Grey |
| Code | EI | JI | KA | NA | TA | UI | RA | C | BI |
| DIN Color Code | | | | | | | | | |
| Color Body | | Blue | Green | | Brown | | White | | Grey |
| Code | | JD | KI | | TI | | RD | | BI |