

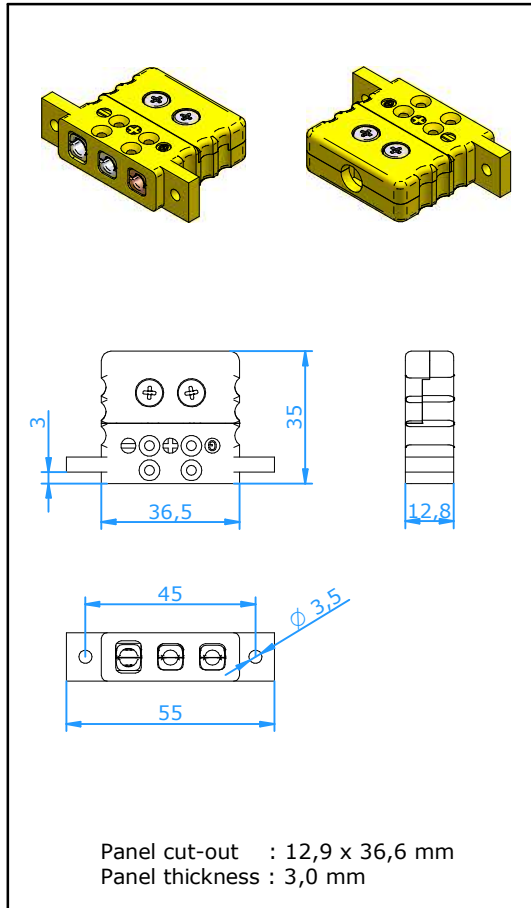

# Panels

## Panel Standard Insert Three Pin Lugged



### Application

Panel insert for thermocouple and RTD circuits.  
Third connection for ground or continuous shield or for three wire RTD's. Can be mounted in a single circuit version or in rows in customer panel. Mounting by means of two M3 screws.

### Construction

- Glass filled thermoplastic body with original thermocouple material pins and springloaded inserts.
- Polarized pins ensure proper connection.
- Central cover screw design for quick wiring.
- Molded barriers prevent short circuit.
- Captive cover screw for easy assembly.

### Wire size

- Accepts wires up to 1,6 mm.
- Maximum cable diameter 8,0 mm.

### Temperature rating

- 220 °C Max.

### Color Code

- Available in all color code standards. Incl. NFE, BS, JIS, etc.

### Accessories

Most accessories for the standard connectors can be fitted. See separate specification sheet.

**Ordering Code :** PSITL-xx

For last two digits 'xx' see table below

Calibration Code	<b>E</b>	<b>J</b>	<b>K</b>	<b>N</b>	<b>T</b>	<b>U</b>	<b>R/S</b>	<b>C</b>	<b>B</b>
Compensation material for							Pt13Rh/ Pt	W5Re/ W26Re	Pt6Rh/ Pt30Rh
Material Positive	NiCr	Fe	NiCr	NiCrSi	Cu	Cu	Cu	CPX	Cu
Material Negative	CuNi	CuNi	NiAl	NiSi	CuNi	Cu	Alloy #11	CNX	Cu
<b>IEC Color Code</b>									
Color Body	Violet	Black	Green	Pink	Brown	White	Orange	Red	Grey
Code	<b>EI</b>	<b>JI</b>	<b>KI</b>	<b>NI</b>	<b>TI</b>	<b>UI</b>	<b>RI</b>	<b>C</b>	<b>BI</b>
<b>ANSI Color Code</b>									
Color Body	Violet	Black	Yellow	Orange	Blue	White	Green	Red	Grey
Code	<b>EI</b>	<b>JI</b>	<b>KA</b>	<b>NA</b>	<b>TA</b>	<b>UI</b>	<b>RA</b>	<b>C</b>	<b>BI</b>
<b>DIN Color Code</b>									
Color Body		Blue	Green		Brown		White		Grey
Code		<b>JD</b>	<b>KI</b>		<b>TI</b>		<b>RD</b>		<b>BI</b>