

MAIN APPLICATIONS

- Plastic extrusion, injection, blow moulding, thermoforming
- Packing and packaging
- Chemical and pharmaceutical industry
- Industrial electric furnaces
- Dryers for ceramics and construction elements
- Food industry processing plants
- Heating systems with infrared lamps (long, medium, short wave)
- Wood binding machines
- Medium and long wave infrared lamps



MAIN FEATURES

- Ultra-compact dimensions from 15A to 120A
- Load voltage 480V, 600V AC
- SCCR 100 kA
- DIN rail and panel mounting
- IO-Link digital communication
- Zero voltage crossing (ZeroCrossing) or Phase angle control.
- On/Off control, optimised/fixed cycle time, HalfSingleCycle, PhaseAngle, soft-start ramps.
- Input command from V DC, Analogue signal (0..5V, 0..10V, 0..20mA, 4..20mA, potentiometer) or IO-Link logic.
- Connectors for push-in control signals; signal LED.
- Configuration and diagnostics via smart-phone app with NFC technology.
- Alarm threshold calibration by button or digital input.
- Compact versions with expanded i²t.
- Cage clamps for power cables
- Advanced diagnostic option with partial load break (up to 8 loads in parallel), current measurement and energy meters.
- Internal over voltage protection
- Integrated cooling fan power option.

PROFILE

The correct management of electric heaters and infrared lamps for industrial heating applications requires robust, safe, fast and diagnostic-capable static contactors.

The range of solid state contactors with heatsink GRP-H meets all these needs, with current ratings from 15 to 120 Ampere, voltages up to 600Vac, in extremely compact dimensions in every single size. The thermal design of all models guarantees the continuous supply of the rated current at an ambient temperature of 40°C / 104°F through high efficiency heat sinks, assisted by fans for the 90A and 120A models. The derating curves show how higher current values can also be obtained for lower temperatures as well as the possibility of mounting various devices stacked on the DIN rail.

CONFIGURATION AND DIAGNOSTICS

For the configuration of the GRP-H series devices, an App is available for smartphones with Android and iOS operating systems, which can be downloaded free of charge from the relative stores. The App interfaces to the device via contactless NFC (Near Field Communication) technology via a small NFC Dongle (which can be ordered as part of the device or as an accessory).

It is also possible to read diagnostic data on the operation of the load and the device (energy meters, current peaks or over-temperatures), duplicate or share the configurations of multiple devices through this interface.

The IO-Link interface guarantees efficient communication, capable of powering, configuring, monitoring and controlling the device, via only 3 wires. Complete and simple device configuration is possible with IODD files.

The devices can also be configured using a special cable via PC and the GF_eXpress configuration tool. Alternatively, basic device configuration is made available by means of a button and LED on the front. The current thresholds for partial load break alarms can be adjusted by means of a front key or digital input, so that multiple objects can be configured at the same time with the electrical panel closed.

CONTROL

The GRP-H series can be controlled in three different ways based on the options chosen:

1. Logic signals in V DC, OnOff mode.

2. Analogue signal configurable as 0..5V, 0..10V, 0..20mA, 4..20mA and potentiometer, for proportional commands (Burstfiring, FixedCycleTime, HalfSingleCycle, PhaseAngle).

3. Control via the IO-Link point-to-point communication protocol for comprehensive process diagnostics.

All commands are managed via push-in connectors, for faster and easier connection, even without tools. The device status is always displayed by a multi-colour LED on the front panel, for an immediate view of its operation. In the event of an error in the command signal, a fault power can be programmed which the device will maintain until the signal is restored.

POWER CONNECTIONS

Both the line voltage terminal available on the upper part of the device and the load terminal on the lower part are of the "cage" type, which offers the best and safest seal even for cables of different cross-sections, whether mounted with a cable lug or simply stripped.

DIAGNOSTICS AND ALARMS

It is increasingly vital for operators and maintainers to recognize possible anomalies in the system immediately and solve them quickly in order to ensure the efficiency and profitability of machinery and plants. The GRP-H series offers complete availability of load information.

The physical alarm output, PNP type, is ready to diagnose partial or total load breaks, lack of voltage on the load and over-temperature (configurable output). The thermal alarm is triggered if heat dissipation exceeds a critical threshold, signalling it with a red led on the front panel, interrupting the power supply and triggering the alarm output.

This function is always present, on all current sizes.

DIMENSIONS AND MOUNTING MEASUREMENTS

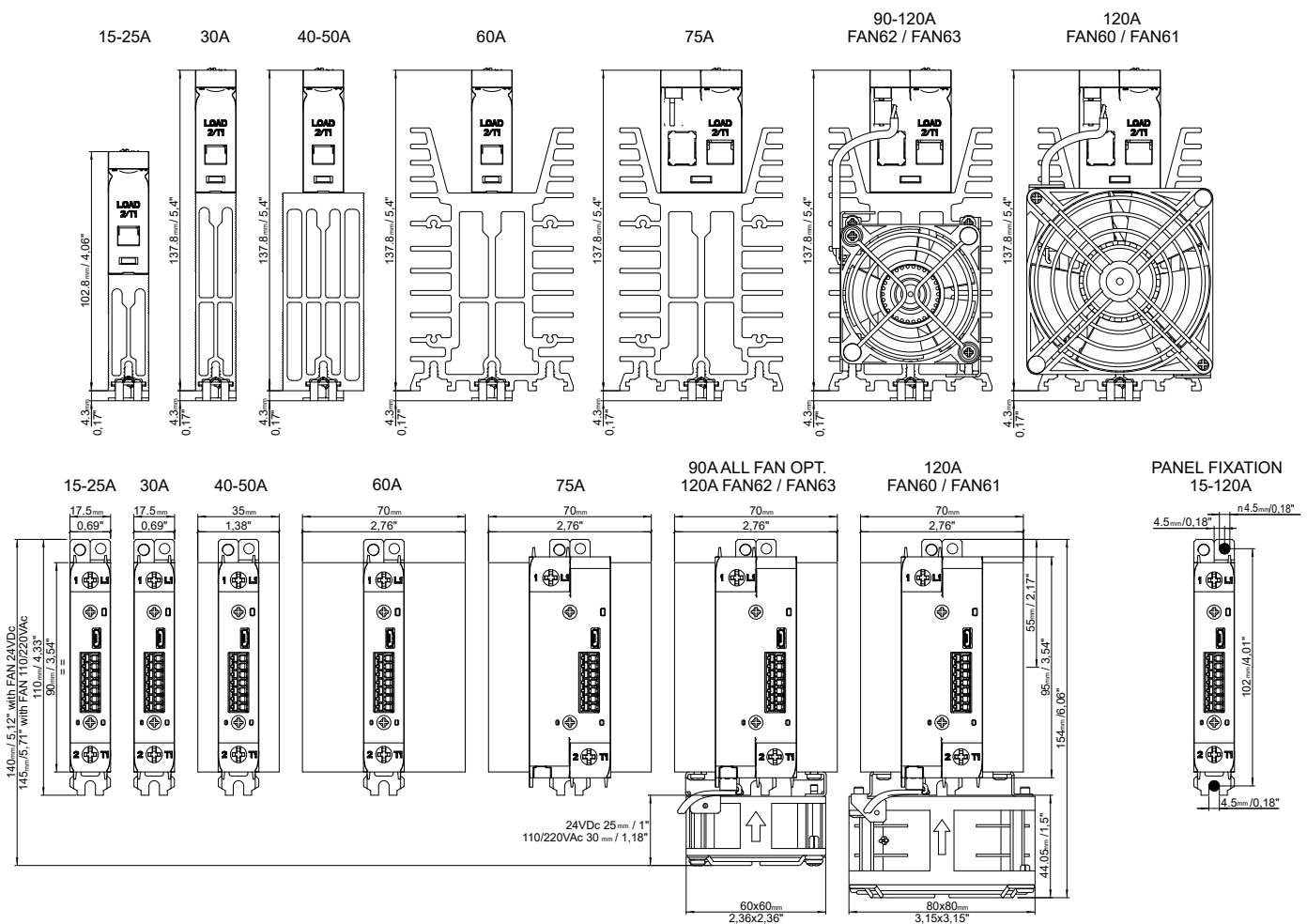

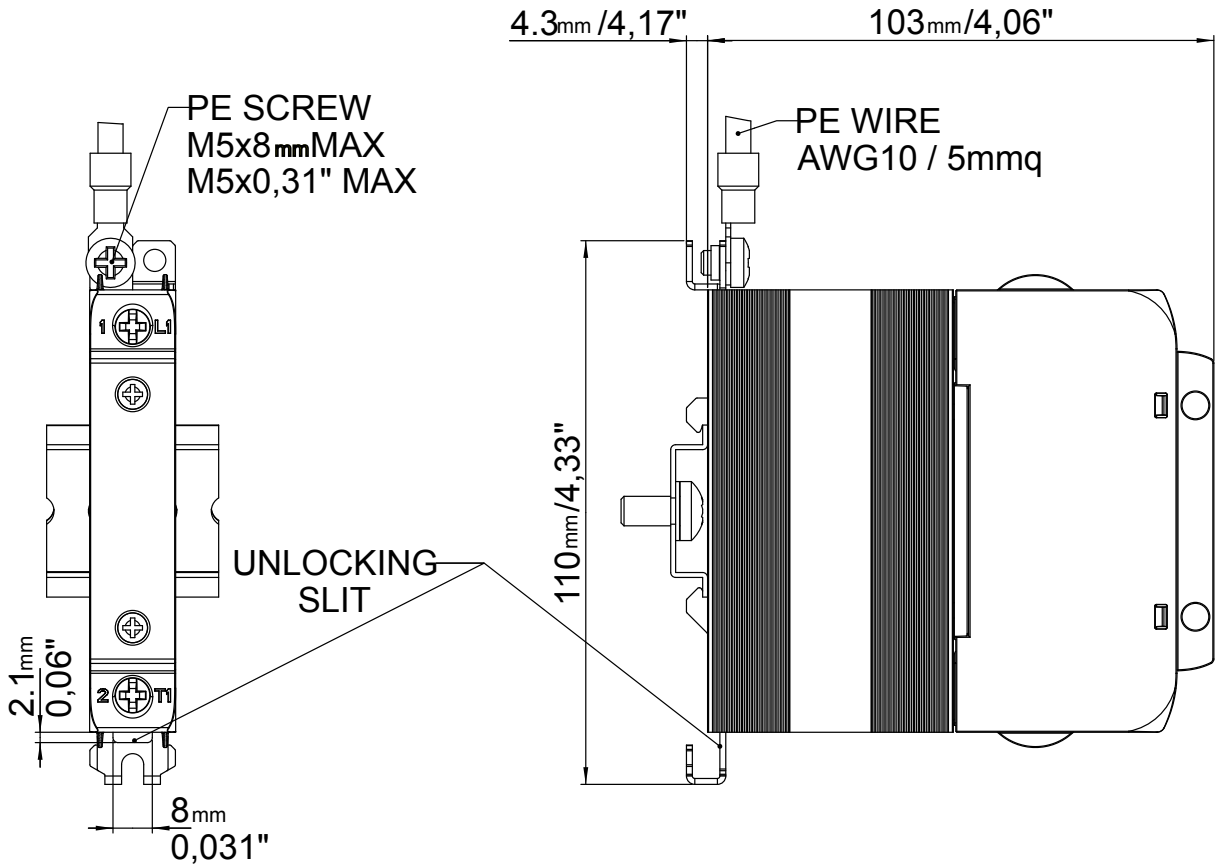

DIN rail coupling sequence

DIN rail release sequence

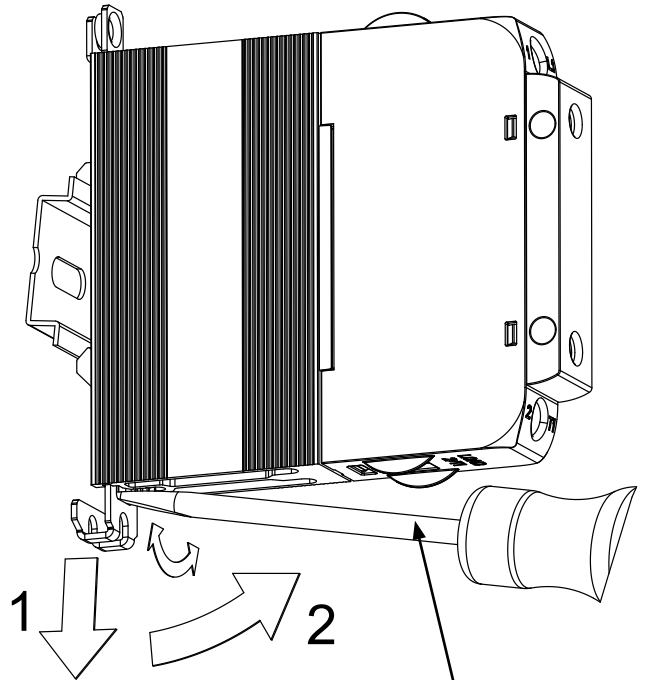
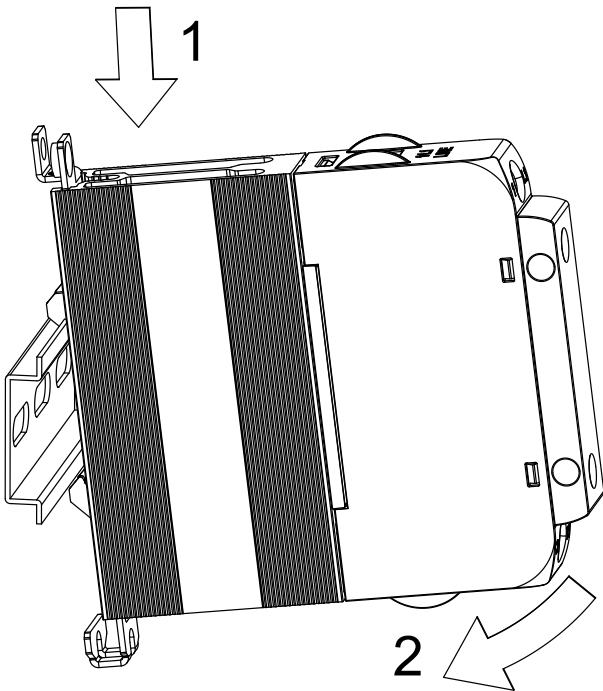

SCREW DRIVER (*)

(*) Use of a slotted screwdriver with a max. diameter of 6mm is recommended

PANEL FIXING

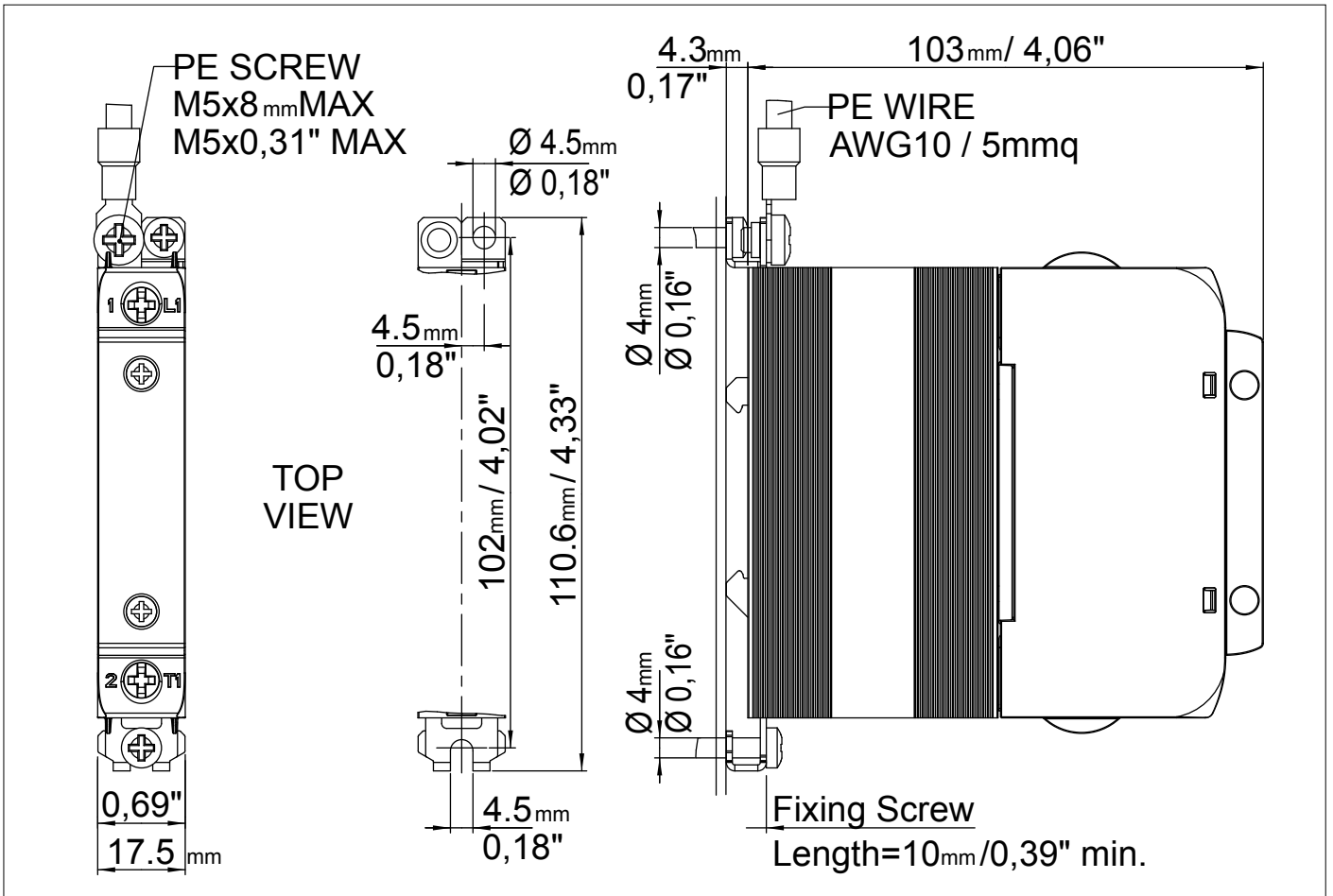

FRONT VIEW

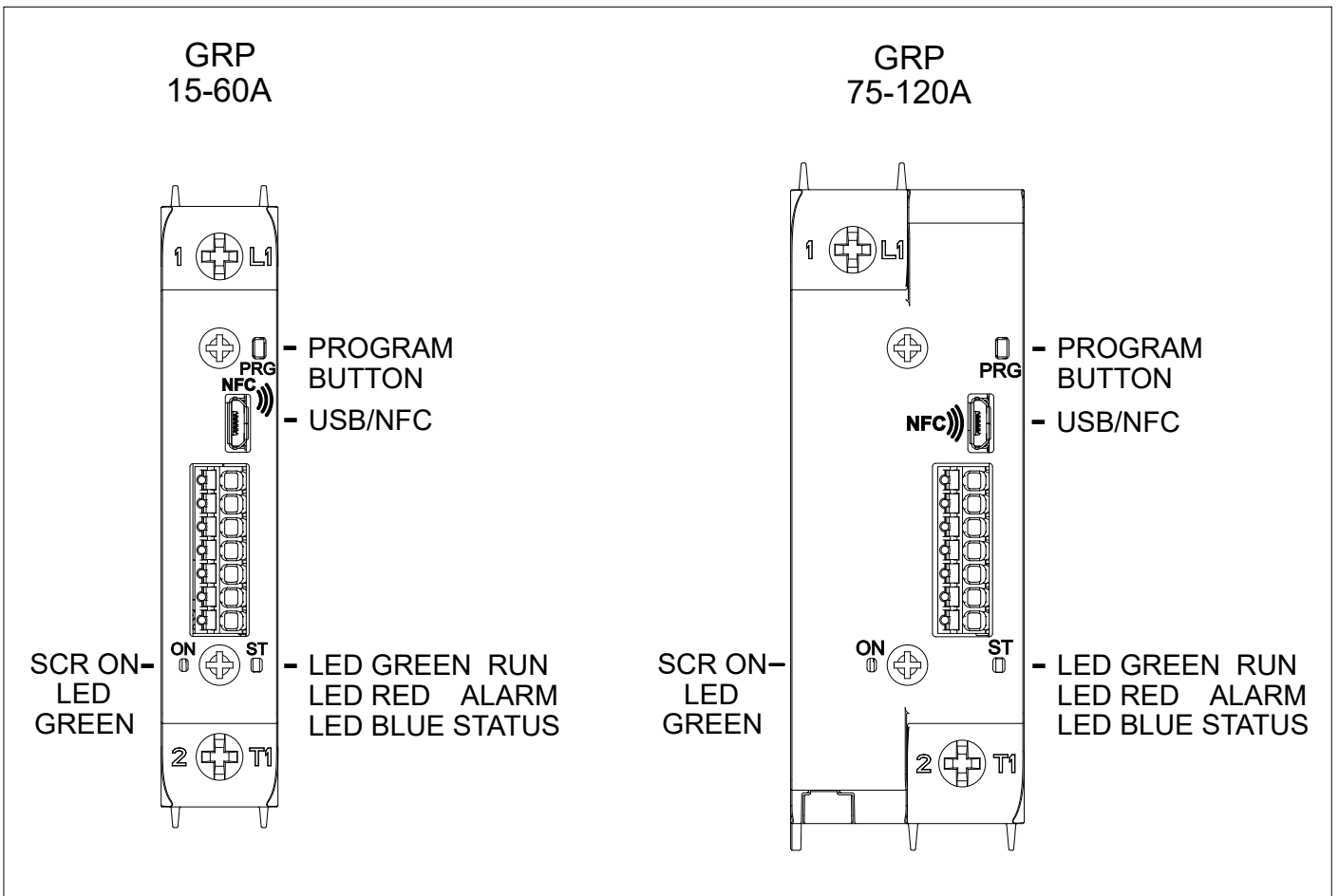

VERSION WITH ANALOGUE INPUT

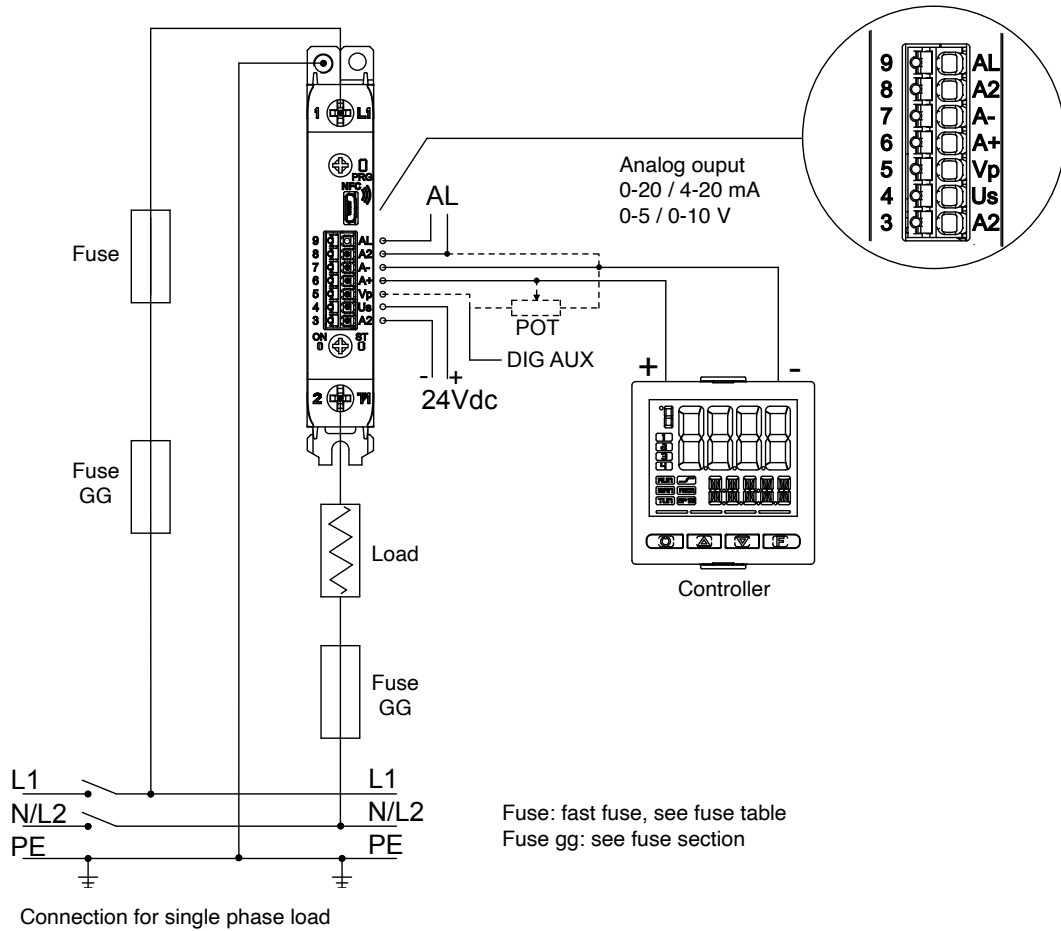

Power terminals		
Ref.	Description	Notes
1/L1	Line Connection	
2/T1	Load Connection	
AN version signal connector (analogue input)		
3/A2-	Power GND	
4/Us	+ V DC power supply	GRP-H power supply (Range from 10 to 30 V DC, I _{max} = 20 mA at 24V) GRP-H-90 ..120A-..FAN63: GRP-H + Fan power supply (Range from 20 to 27 V DC, I _{max} <150 mA at 24V with Fan active)
5/Vp	Potentiometer power supply output (+ 5Vdc) / Auxiliary digital input	Potentiometer output voltage: 5V DC, I _{out} max = 10mA Digital input: 5-30V max 3 mA
6/A+	Analogue differential command input	
7/A-		
8/A2-	GND alarm output (common to terminal 3/A2-)	
9/AL	Alarm output	Digital output normally off (settable with normally on). PNP type, output voltage: Us(24Vdc)-0.7Vdc, I _{out} max =15mA

VERSION WITH DIGITAL INPUT

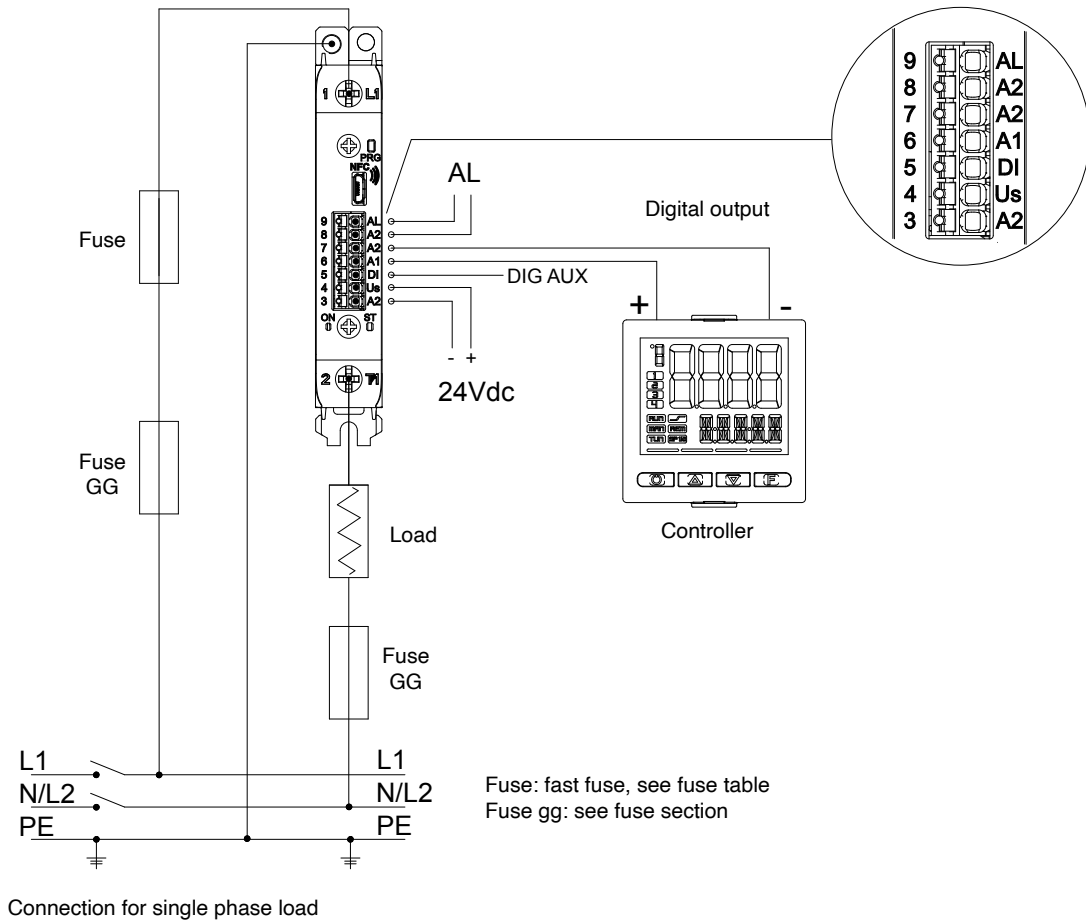

Power terminals		
Ref.	Description	Notes
1/L1	Line Connection	
2/T1	Load Connection	
Connettore di segnale versioni D (ingresso digitale)		
3/A2-	Power GND	
4/Us	+ V DC power supply	GRP-H power supply (Range from 10 to 30 V DC, I _{max} = 20 mA at 24V) GRP-H-90..120A-..FAN63: GRP-H + Fan power supply (Range from 20 to 27 V DC, I _{max} <150 mA at 24V with Fan active)
5/DI	Auxiliary digital input	Digital input: 5-30V max 3 mA
6/A1+	Command digital input	Digital input: 5-30V max 3 mA
7/A2-	GND command input (common to terminal 3/A2-)	
8/A2-	GND alarm output (common to terminal 3/A2-)	
9/AL	Alarm output	Digital output normally off (settable with normally on). PNP type, output voltage: U _s (24Vdc)-0.7Vdc, I _{out} max =15mA

VERSION WITH IO-LINK INPUT

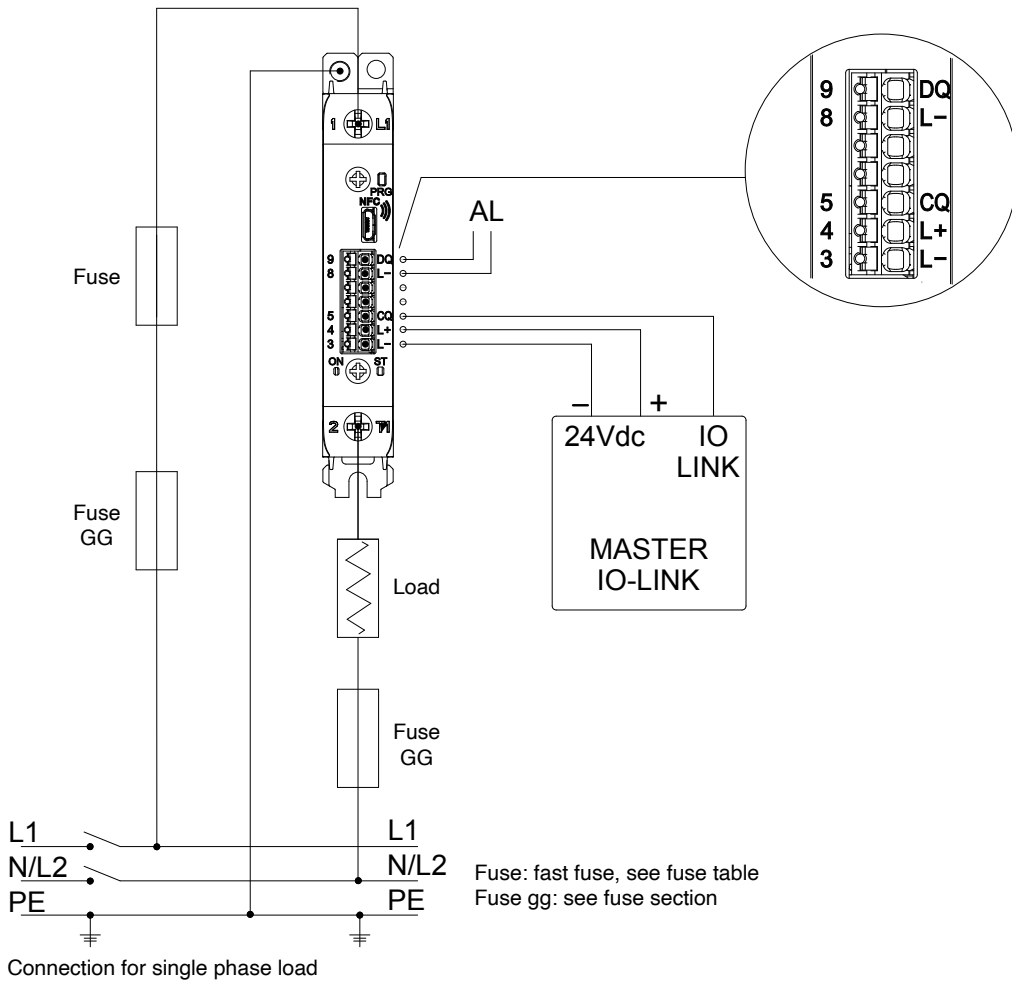

Power terminals (common to all versions)		
Ref.	Description	Notes
1/L1	Line Connection	
2/T1	Load Connection	
I version signal connector (IO-LINK)		
3/L-	Power GND	
4/L+	+ V DC power supply	GRP-H power supply (Range from 10 to 30 V DC, I _{max} = 20 mA at 24V) GRP-H-90..120A..FAN63: GRP-H + Fan power supply (Range from 20 to 27 V DC, I _{max} <150 mA at 24V with Fan active)
5/CQ	IO-LINK communication line	
8/L-	GND alarm output (common to terminal 3/L-)	
9/DQ	Alarm output	Digital output normally off (settable with normally on). PNP type, output voltage: U _s (24Vdc)-0.7Vdc, I _{out} max =15mA

DERATING CURVES

Rated current curves as a function of ambient temperature (minimum distance between GRP-H of 20mm).

GRP-H 15 ÷ 30A DERATING CURVES

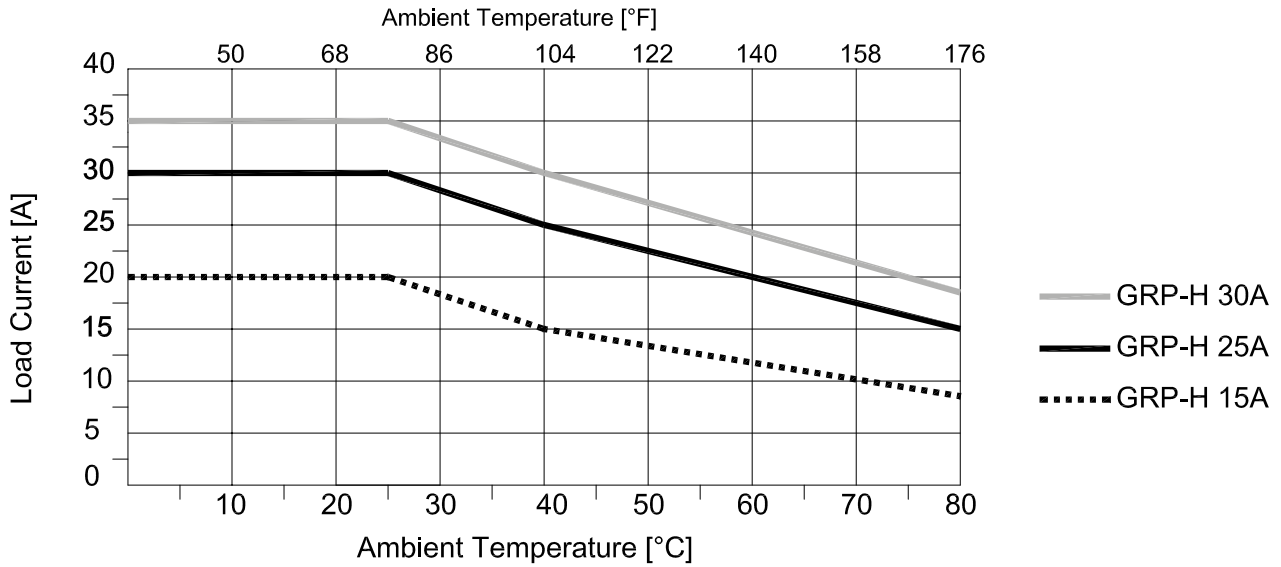

GRP-H 40 ÷ 60A DERATING CURVES

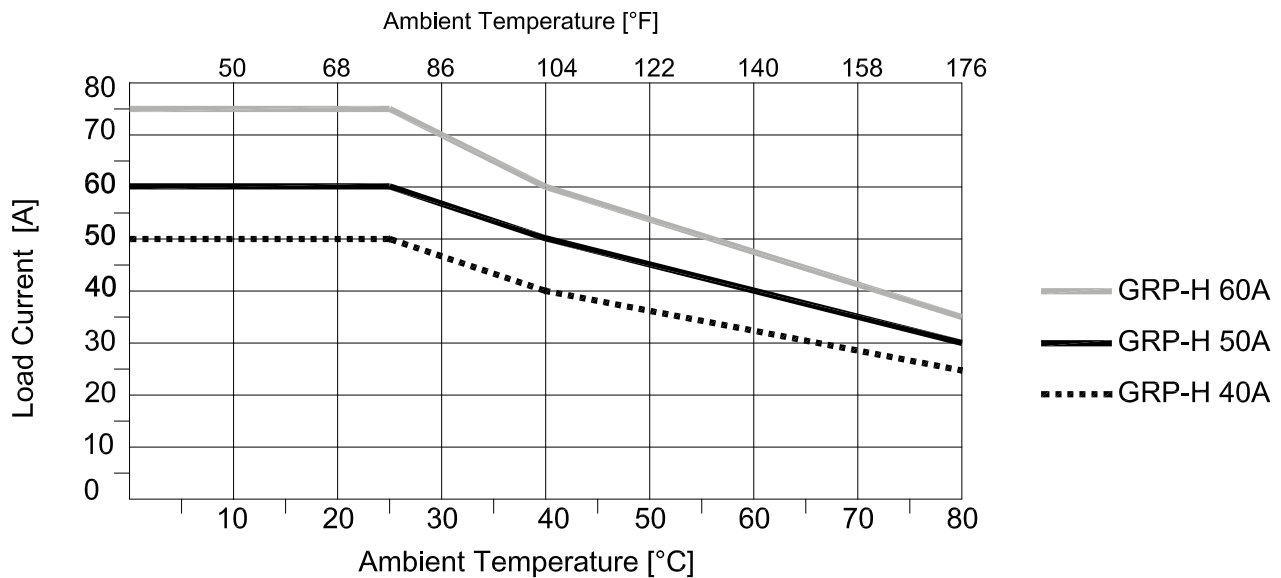

GRP-H 75 ÷ 120A DERATING CURVES

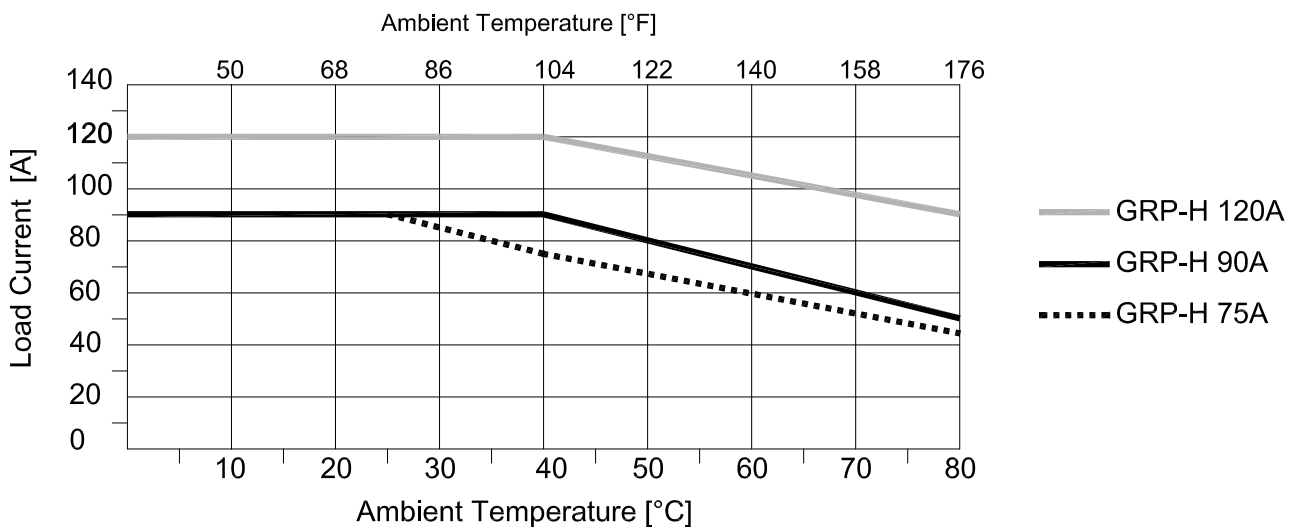

Note: The curves of GRP-H 90/120A refer to the device complete with a working specified fan

DOWNGRADE WITH INSTALLATION DISTANCE

Rated current curves as a function of the horizontal distance between the GRP-Hs (ambient temperature 40°C / 104°F).

GRP-H 15 ÷ 30A DERATING CURVES

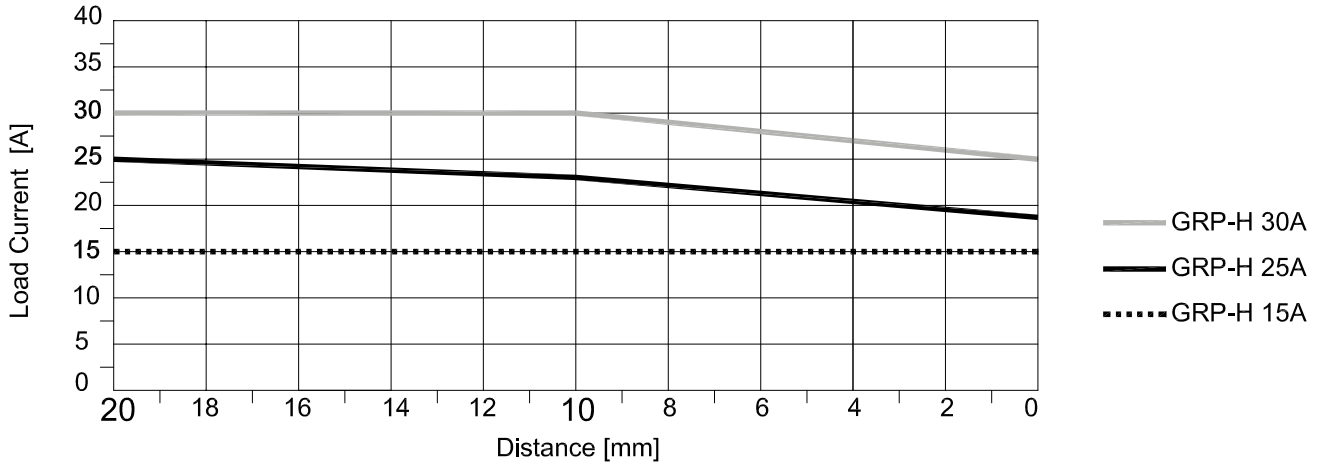

GRP-H 40 ÷ 60A DERATING CURVES

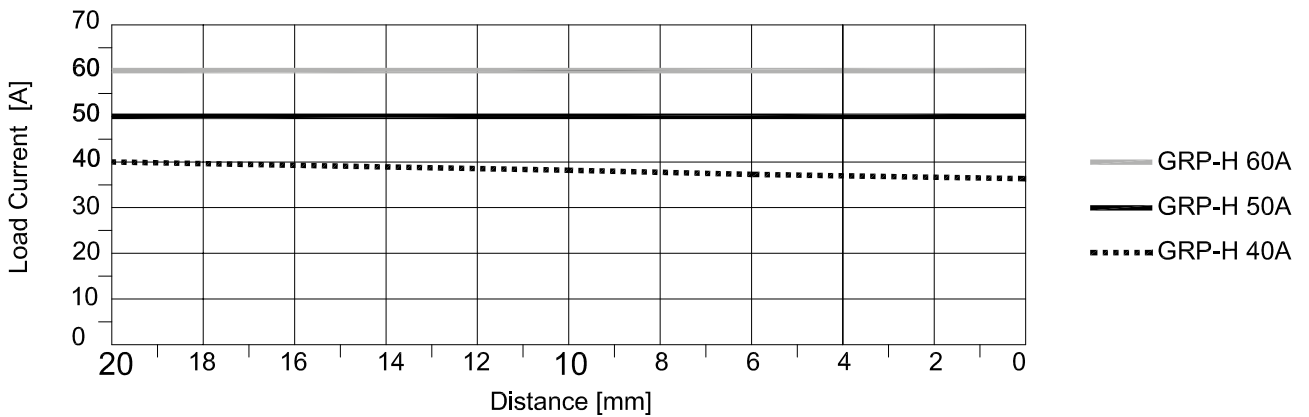

GRP-H 75 ÷ 120A DERATING CURVES

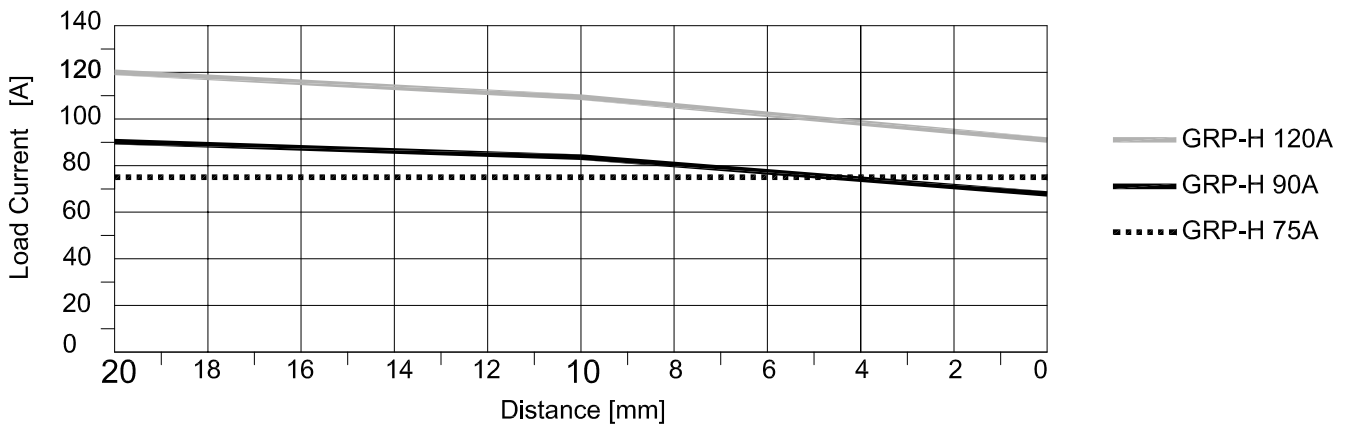

Note: The curves of GRP-H 90/120A refer to the device complete with a working specified fan

TECHNICAL SPECIFICATIONS

INPUTS	
Analogue command input (Versions with AN input type)	
Function	Command power command
Maximum Error	1% f.s. \pm 1 scale point at an ambient temperature of 25°C/ 77°F
Thermal shift	<100 ppm/° C on f.s.
Sampling time	10 ms
0-10V scale	Input impedance > 500 K Ω
0-5V scales	Input impedance > 500 K Ω
0-20mA or 4-20mA scale	Internal Shunt Resistance: 250 Ω
Potentiometer input	Potentiometer resistance: 1 K Ω at 47 K Ω Potentiometer power supply: + 5V (provided by GRP, max 10mA)
Linear input reading scale	0 ... 100.0 %
Common mode immunity	-60V, +60V
Command digital input (Versions with input type D)	
Function	Command input
Voltage range	5-30V (max 3 mA)
Safe voltage reading status "0"	< 2 V
Safe voltage reading status "1"	> 5 V
Input impedance	13 K Ω
IO-LINK input (Versions with input type I)	
Function	IO-LINK fieldbus communication line
Protocol	IO-LINK Type of transmission: COM2 (38.4 kBaud) IO-Link version: 1.1.2 SIO mode: No Auxiliary output: Pin DQ Alarm output
Process data input	14 bytes
Process data output	2 bytes
Line voltage and load current measurement	
Load current measurement function	Measurement range (full-scale f.s.): 0 ... 1.5 * I _{rated_product}
RMS current measurement accuracy	2% f.s. at room temperature of 25°C / 77°F Thermal shift: <200 ppm/° C
Line voltage measurement function	Working voltage range (full-scale f.s.): 60...660Vac
RMS voltage measurement accuracy	2% f.s. at room temperature of 25°C / 77°F Thermal shift: <100 ppm/° C
Current and voltage sampling time	10 ms
Line frequency	50/60 Hz
OUTPUTS	
Alarm output (optional)	
Function	Configurable alarm output
Type	Digital output normally off (settable with normally on). PNP type, output voltage: U _s (24Vdc)-0.7Vdc, I _{out} max =15mA (not protected against short circuit)
COMMUNICATIONS PORTS	
Porta microUSB di servizio	
Functions with TTL serial cable	Only for initial product configuration, via PC. Use a PC connected to the GRP, ONLY via the Gefran adapter cable. The adapter powers the GRP. Cod. F060800 (PC with USB).
Type	Micro USB type B connector
Insulation	TTL serial NOT isolated
Funzione Dongle NFC:	Disponibile per la configurazione, lettura di Informazioni sul prodotto e dati di diagnostica. Utilizzare App scaricabile da PlayStore ed AppleStore e Dongle NFC (vedi tabella accessori)

POWER (STATIC GROUP)												
CATEGORY OF USE (Tab. 2 EN60947-4-3)	AC 51: resistive or low-inductance loads AC 55b: infrared lamps											
Trigger modes	OnOff - Zero crossing firing. FCT- Fixed Cycle Time - Zero Crossing with constant cycle time (settable in the range 1...200 sec). BF - Burst Firing with optimised minimum variable cycle time (Zero crossing firing). HSC - Half Single Cycle, corresponds to a Burst Firing which handles half on/off cycles (Zero crossing firing). PA - load management by adjusting the power-on phase angle. It is useful for reducing flicker with medium-long wave infrared loads. Softstart ramp in Phase Angle configurable with any configured Firing mode, only for products with Trigger option = 2 or 3 .											
Max. rated voltage	480 V AC						600 V AC					
Working voltage range	60-530Vac						60-660Vac					
Non-repetitive voltage (Surge protection level)	1200 Vp						1400 Vp					
Rated frequency	50/60Hz with auto-determination											
Rated current	GRP Model											
	15	25	25I	30	30I	40	50	60	75	90	120	
	15A	25A	25A	30A	30A	40A	50A	60A	75A	90A	120A	
Non-repetitive over-current, (t=20 msec)	620A	620A	1600A	620A	1600A	620A	1600A	1600A	1600A	1500A	1500A	
I ² t for melting (t = 1... 10msec) A ² s	1800	1800	12800	1800	12800	1800	12800	12800	12800	11250	11250	
critical dv/dt with output disabled	1000 V/μs											
Rated impulse withstand voltage	4kV											
Rated current in short circuit condition	5kA											
Minimum load current:	1 A											
Voltage drop over rated current:	= < 1,2Vrms											
Presence of leakage current:	< 3mA (Maximum value with nominal Voltage and Junction temperature of 125°C / 257°F)											
Calculation Of The Power Dissipated By The Solid State Relay	Single-phase static relay Pd = 1.2 * IRMS [W] (for GRP) IRMS = single-phase load current											
Calculation Of The Power Dissipated By The Solid State Relay	Single-phase static relay Pd = 1.2 * IRMS [W] IRMS = single-phase load current Example: load current=20Arms, Thermal power dissipated: Pd=20*1,2= 24 W											
Calculation Of The Heatsink's Thermal Resistance	Rth = (90°C - T.amb. max) / Pd with Pd = power dissipation Max amb. T.= maximum air temperature in the electrical cabinet. Use a heatsink with lower than calculated heat resistance (Rth). Example: Thermal power dissipated: Pd=20*1,2= 24 W T.amb.max = 40°C Rth = (90-40)/24=2,08[°C/W]											

OPTIONS		
Basic Diagnostics on PNP digital output (Option 0)	- Power failure for: SCR open / Load interrupted / No line voltage - Overheating alarm	
Advanced Diagnostics on digital output PNP (Option 1)	- Power failure for: SCR open / Load interrupted / No line voltage - Overheating alarm SCR short circuit (current presence with OFF command). HB (Heat Break) Alarm: - HB alarm load interrupted or partially interrupted, up to 8 loads in parallel. - Automatic calibration of the HB alarm threshold based on the current load level. The alarm threshold default is 90%, of the current read in calibration. Value corresponding to the recommended threshold to intercept the breakdown up to 1/5 of the total load. Threshold can be changed with the appropriate parameter via NFC App, IO-Link and GF_eXpress, or via front button. Note 1: with Digital command turn ON minimum time = 50 ms to detect broken load. Note 2: For proper operation of the partial load failure alarm even under the most critical conditions (8 equal loads in parallel), it is necessary that the total load current (non-fault) is at least 30% of the rated current of the GRP (on a 15A GRP -->4.5A) Example: a 15A GRP of nominal size drives 8 equal resistors in parallel. To diagnose the failure of only one of the 8 loads in parallel, the single load must have a draw of at least 0.56A, the total load must draw at least 4.5A (0.56A *8 loads).	
GENERAL CHARACTERISTICS		
Power supply	10... 30 V DC \pm 10%, absorption 20 mA at 24 V DC (Range from 20 to 27 V DC, I _{max} <150 mA at 24V with Fan active)	
Indications	2 leds: ON (Green LED): Control status of the thyristor STATUS (RGB LED): State of operation	
Protection rating	IP20	
Working temperature	0...80°C (32 ... 176°F) (see derating curves)	
Storage temperature	-20°C - +85°C (-4 ... 185°F) average temperature in a period of 24H not higher than 35°C (95°F) (according to EN 60947-4-3 § 7.1.1)	
Maximum relative humidity	90% non-condensing	
Environmental conditions of use	Indoor use, maximum altitude 2000m For higher altitudes consider: -Decreasing 1% of rated current for every 100m (328ft) above elevation 2000m (6562ft). -Decreasing of maximum voltage by correction factor: 0.88 from 2000 (6562ft) to 3000m (9842ft) 0.77 from 3001 (9846ft) to 4000m (13123ft) 0.68 from 4001 (13127ft) to 5000m (16404ft) Example for GRP-.25-60.. at 2800 mslm (9186ft) - 25A nominal derated by 1%*8-->23A - 600Vac nominal, maximum voltage 660Vac derated to 660*0.88=580.8Vac	
Installation	DIN EN50022 bar or panel mount by screws	
Installation requirements	Installation category II, pollution degree 2 Maximum air temperature around the device 40°C / 104°F (for Temperature > 40°C / 104°F see derating curves)	
Weight	GRP-H 15, 25A, 25I	194 g / 6.84 Oz
	GRP-H 30A, 30I	237 g / 8.36 Oz
	GRP-H 40, 50A	388 g / 16.69 Oz
	GRP-H 60, 75A	688 g / 24.27 Oz
	GRP-H 90A	796 g / 28.09
	GRP-H 120A	796 g / 28.09

PROTECTION FUSES

Type 1 and Type 2 coordination are ratings based on the level of protection and resilience provided during a high current fault. Device is designed to protect people and equipment during a short circuit fault, but the differences between the two levels can be explained as follows:

Type 1 : after a short circuit event it may be too damaged for further use.

Type 2 : after a short circuit event device will still be in working.

Protection co-ordination (Type 2)

Size device	Fuse nominal Current	Model and fuse size (manufacturer Bussmann Div Cooper (UK) Ltd)	Fuse code (descr.)	Fuse holder accessory code (descr.)
15	16	FWC-16A10F 10x38	338470 (FUS-016)	337132 (PF-10x38)
25,25I	25	FWC-25A10F 10x38	338474 (FUS-025)	
30,30I	32	FWC-32A10F 10x38	338483 (FUS-032)	
40	40	FWP-40A14F 14x51	338147 (FUS-040)	337131 (PF-14x51)
50	50	FWP-50A14F 14x51	338079 (FUS-051)	
60	63	FWP-63A22F 22x58	338191 (FUS-063)	337130 (PF-22x58)
75	80	FWP-80A22F 22x58	338199 (FUS-080)	
90	100	FWP100A22F 22x58	338478 (FUS-100)	
120	125	170M1418 000-TN/80	338106 (FUS-100)	337092 (PF-DIN)

Protection co-ordination (Type 1) according to UL 508

The devices are suitable For Use On A Circuit Capable Of Delivering Not More Than 100,000 A rms Symmetrical Amperes, 600 Volts Maximum when Protected by UL Listed fuses with size and class as specified in the table below:

Size device	Fuse Class	Fuse Current Max Size [A]	Prospective short circuit current [kArms]
15, 25 , 30	J	40	100
	CC	30	
40	J	40	
25I		80	
30I		80	
50		80	
60		80	
75		80	
90		125	
120		125	

Use Fuses Only.

GG FUSES

An electrical protection device known as a GG FUSE must be used to ensure protection against short-circuit of the electrical cable (see EN 60439-1, paragraph 7.5 Short-circuit protection and short-circuit withstand strength” and 7.6 “Switching devices and components installed in ASSEMBLIES”, or the equivalent paragraphs of standard EN 61439-1).

MCB protection

Protection co-ordination (Type 2) with Siemens Miniature Circuit Breaker (MCB / Thermal-Magnetic) 5SY4 series, curve A, 1P and 2P						
Current size model (I2t)	Current size model (I2t)	Current size model (I2t)	Current size model (I2t)	Current size model (I2t)	Current size model (I2t)	Current size model (I2t)
GRP(-H)-15,25,30,40 (1800 A²s)	5SY4110-5 (10)	1,0	6,0	5SY4210-5 (10)	1,0	6,0
		1,5	9,0		1,5	10,0
		2,5	14,0		2,5	14,0
	5SY4116-5 (16)	1,0	6,0	5SY4216-5 (16)	1,0	6,0
		1,5	9,0		1,5	10,0
		2,5	14,0		2,5	14,0
		4,0	15,0		4,0	25,0
	5SY4120-5 (20)	1,5	9,0	5SY4220-5 (20)	1,5	10,0
		2,5	15,0		2,5	21,0
		4,0	30,0		4,0	30,0
	5SY4125-5 (25)	2,5	18,0	5SY4225-5 (25)	2,5	18,0
		4,0	30,0		4,0	30,0
	5SY4132-5 (32)	2,5	21,0	5SY4232-5 (32)	2,5	36,0
		4,0	35,0		-	-
GRP(-H)-25I, 30I, 50, 60,75 (12800 A²s)	For MCBs smaller than those indicated in the lines below, there are no section and length constraints.					
	5SY4132-5 (32)	2,5	2,0	5SY4232-5 (32)	2,5	2,0
		4,0	4,0		4,0	4,0
		6,0	7,0		6,0	7,0
	5SY4140-5 (40)	4,0	4,0	5SY4240-5 (40)	4,0	4,0
		6,0	7,0		6,0	7,0
		10,0	10,0		10,0	10,0
	5SY4150-5 (50)	6,0	7,0	5SY4250-5 (50)	6,0	7,0
		10,0	10,0		10,0	10,0
		16,0	18,0		16,0	18,0
	5SY4163-5 (63)	6,0	7,0	5SY4263-5 (63)	6,0	7,0
		10,0	10,0		10,0	10,0
		16,0	18,0		16,0	18,0
	GRP(-H)-90,120 (11250 A²s)	For MCBs smaller than those indicated in the lines below, there are no section and length constraints.				
5SY4132-5 (32)		2,5	2,0	5SY4232-5 (32)	2,5	2,0
		4,0	4,0		4,0	4,0
		6,0	7,0		6,0	7,0
5SY4140-5 (40)		4,0	4,0	5SY4240-5 (40)	4,0	4,0
		6,0	7,0		6,0	7,0
		10,0	10,0		10,0	10,0
5SY4150-5 (50)		6,0	7,0	5SY4250-5 (50)	6,0	7,0
		10,0	10,0		10,0	10,0
		16,0	18,0		16,0	18,0
5SY4163-5 (63)		6,0	7,0	5SY4263-5 (63)	6,0	7,0
		10,0	10,0		10,0	10,0
		16,0	18,0		16,0	18,0

* The sizing is valid for a 230Vac phase-neutral line with an assumed short-circuit current of 2,5KA

** The sizing is valid for a 400Vac phase-to-phase line with an assumed short-circuit current of 5KA

*** The length of the cable is intended between MCB and load, including the return to neutral (1P case), or to the second pole of the MCB (2P case).

Example, for a GRP-H-50- ..., with line voltage of 230Vac, controlled load of 45 A nominal, with a section of 6mm² of cable, an MCB 5SY4150-5 (50 A) the minimum length of the cables is 7m (cable length is intended between MCB and load, including return).

EMC STANDARDS

EMC emissions

AC semiconductor motor controllers and conductors for non-motor loads	EN 60947-4-3	Class A Group 2
Emission enclosure CI compliant in firing mode single cycle and phase angle if external filter fitted	EN 60947-4-3 CISPR-11 EN 55011	

EMC Immunity

Generic standards, immunity standard for industrial environments	EN 60947-4-3	
ESD immunity	EN 61000-4-2	4 kV contact discharge 8 kV air discharge
RF interference immunity	EN 61000-4-3 /A1	10 V/m amplitude modulated 80 MHz-1 GHz 10 V/m amplitude modulated 1.4 GHz-2 GHz
Conducted disturbance immunity	EN 61000-4-6	10 V/m amplitude modulated 0.15 MHz-80 MHz
Burst immunity	EN 61000-4-4	2 kV power line 2 kV I/O signal line
Surge immunity	EN 61000-4-4/5	Power line-line 1 kV Power line-earth 2 kV Signal line-earth 2 kV Signal line-line 1 kV
Magnetic fields immunity	Test are not required. Immunity is demonstrated by the successfully completion of the operating capability test	
Voltage dips, short interruptions and voltage immunity tests	EN 61000-4-11	100%U, 70%U, 40%U

LVD safety

Safety requirements for electrical equipment for measurement, control and laboratory use	EN 61010-1
--	------------

CAUTION

This product has been designed for class A equipment. Its use in a domestic environment may cause radio interference, in which case the user may be required to use additional attenuation methods.

EMC filters are required in PA operating mode (Phase Angle, i.e., SCR triggering with a modulated phase angle). The filter model and current size depend on the configuration and the load used. It is important that the power filter is connected as close as possible to the GRP-H. A filter connected between the power supply line and the GRP-H or an LC unit connected between the GRP-H output and the load may be used.

ORDER CODE

GRP-H - A - B - C - D - E - F - G - H - I

Rated current	
15Aac	15
25Aac	25
25Aac I2t++	25I
30Aac	30
30Aac I2t++	30I
40Aac	40
50Aac	50
60Aac	60
75Aac	75
90Aac	90
120Aac	120

Rated voltage	
480Vac	48
600Vac	60

Control type	
Digital with advanced diagnostics	D-1
Analogue with basic diagnostics	AN-0
Analogue with advanced diagnostics	AN-1
IO-Link with advanced diagnostics	I-1

For models from 15 A to 76 A	
None	0
Ventola per modelli 90A/120A	
230V AC 60x60x30mm for 90A models	FAN60
230V AC 80x80x38mm for 120A models	
115V AC 60x60x30mm for 90A models	FAN61
115V AC 80x80x38mm for 120A models	
24Vdc 60x60x25mm	FAN62
24V DC 60x60x25mm integrated power supply	FAN63

Note:

Basic diagnostics: includes thermal safety, thermal alarm, total load break, no line voltage
Advanced diagnostics: Basic diagnostics, current reading, partial load break.



Future developments

NFC Dongle accessory	
0	Absent
1	NFC Dongle included

Trigger	
with D-1 type control	
0	OnOff
with AN-0 type control	
1	Burst Firing (optimised or fixed cycle time)
with AN-1 and I-1 type control	
1	Burst Firing (optimised or fixed cycle time)
2	Half Single Cycle (default), also configurable as Phase Angle or Burst Firing
3	Phase Angle (default), also configurable as Half Single Cycle or Burst Firing

Control terminal	
0	Push In

CE Conformity Declaration is available on web site www.gefran.com

	This device conforms to European Union Directive 2014/30/EU and 2014/35/EU as amended with reference to generic standards: EN 61000-6-2 (immunity in industrial environment) EN 61000-6-4 (emission in industrial environment) - EN 61010-1 (safety regulations).
	cULus listed, Conformity UL508 - File: E243386
	Short Circuit Current Rating 100KA / 600V according to UL 508

