

MAIN APPLICATIONS

- Extrusion, injection, blow moulding,
- thermoforming of plastics
- Synthetic fibre production and polymerisation
- Packing and packaging
- Chemical and pharmaceutical industry
- Industrial furnaces for heat treatments, metallurgy
- Fusion, sinterization, nitration furnaces
- Furnaces for ceramics and precious metals
- Dryers
- Heating systems with infrared lamps (long-, medium-, short-wave)
- Wood edge banding Machines
- Plastic-blowing Machines
- Welding applications on Packaging Machinery
- Thermoforming Machines
- Furnaces with Super Kanthal™ Silicon carbide heating elements



MAIN FEATURES

- Ultra-compact dimensions from 10A to 120A
- Load voltage 480V, 600V AC
- IO-Link and Modbus RTU digital communication
- Current limiting
- Feedback V, I, V², I², P, Z
- Control output for Slave (2PH, 3PH)
- Opzione ad elevata accuratezza di controllo
- Zero voltage crossing (ZeroCrossing) or Phase angle control
- On/Off control, optimised/fixed cycle time, HalfSingleCycle, PhaseAngle, softstart ramps
- Input command, Analogue signal (0..5V, 0..10V, 0..20mA, 4..20mA, potentiometer), PWM or IO-Link logic
- Signal LED
- Configuration and diagnostics via smartphone app with NFC technology

PROFILE

Power control of complex loads needs special precautions. This is for example the case with infrared lamps, or Silicon Carbide heating elements. These kind of electrical loads have not to a constant current absorption during the work phases. This means that at startup when cold, you could have currents up to 15 times higher than the rated current of the load. To avoid that these phenomena cause breakdowns or downtime, the GRM continuously monitors the absorption current and with special algorithms it limits it up to achievement of optimal conditions. The GRM is able to guarantee a stable supply of the energy to the load by compensating for fluctuations of the voltage on the electricity grid, due to variations in the temperature of the loads and the aging of the heating elements. Thanks to the feedback algorithms (feedback in V², I² and P) is always delivered same amount of energy. The range of ultra-compact power controllers GRM-H meets all these needs, with sizes of current from 10 to 120 Ampere, voltages up to 600Vac.

The range of solid state contactors with heatsink GRM-H meets all these needs, with current ratings from 10 to 120 Ampere, voltages up to 600Vac, in extremely compact dimensions in every single size.

The thermal design of all models guarantees the continuous supply of the rated current at an ambient temperature of 40°C / 104°F through high efficiency heat sinks for GRM-H serie, assisted by fans for the 90A and 120A models.

When an integrated heatsink is included the derating curves show how higher current values can also be obtained for lower temperatures as well as the possibility of mounting various devices stacked on the DIN rail.

CONFIGURATION AND DIAGNOSTICS

For the configuration of the GRM series devices, an App is available for smartphones with Android and iOS operating systems, which can be downloaded free of charge from the relative stores. The App interfaces to the device via contactless NFC (Near Field Communication) technology via a small NFC Dongle (which can be ordered as part of the device or as an accessory). It is also possible to read diagnostic data on the operation of the load and the device (energy meters, current peaks or over-temperatures), duplicate or share the configurations of multiple devices through this interface.

The IO-Link interface guarantees efficient communication, capable of powering, configuring, monitoring and controlling the device, via only 3 wires, complete and simple device configuration is possible with IO-Link files.

The devices can also be configured using a special cable via PC and the GF_eXpress configuration tool.

Alternatively, basic device configuration is made available by means of a button and LED on the front.

The current thresholds for partial load break alarms can be adjusted by means of a front key or digital input, so that multiple objects can be configured at the same time with the electrical panel closed.

CONTROL

The GRM series can be controlled in different ways based on the options chosen:

- Command signal configurable as 0..5V, 0..10V, 0..20mA, 4..20mA, potentiometer and PWM, for proportional commands (Burstfiring, FixedCycleTime, HalfSingleCycle, PhaseAngle).

- Control via the IO-Link point-to-point communication protocol for comprehensive process diagnostics.

- Control and diagnostics via the Modbus RTU RS485 communication protocol, with MR option (compatible with analog input model).

All commands are managed via push-in connectors, for faster and easier connection, even without tools.

The device status is always displayed by a multi-colour LED on the front panel, for an immediate view of its operation. In the event of an error in the command signal, a fault power can be programmed which the device will maintain until the signal is restored.

POWER CONNECTIONS

Both the line voltage terminal available on the upper part of the device and the load terminal on the lower part are of the "cage" type, which offers the best and safest seal even for cables of different cross-sections, whether mounted with a cable lug or simply stripped.

DIAGNOSTICS AND ALARMS

It is increasingly vital for operators and maintainers to recognize possible anomalies in the system immediately and solve them quickly in order to ensure the efficiency and profitability of machinery and plants. The GRM series offers complete availability of load information.

There are 3 physical outputs, two are PNP type and one voltage-free normally open contact.

The outputs can be configured and associated with different alarm states: partial or total breakages of the load, lack of voltage on the load, faults on the line, over temperature.

The thermal alarm is triggered if heat dissipation exceeds a critical threshold, signalling it with a red led on the front panel, interrupting the power supply and triggering the alarm output.

This function is always present, on all current sizes.

HEATSINK MOUNTING

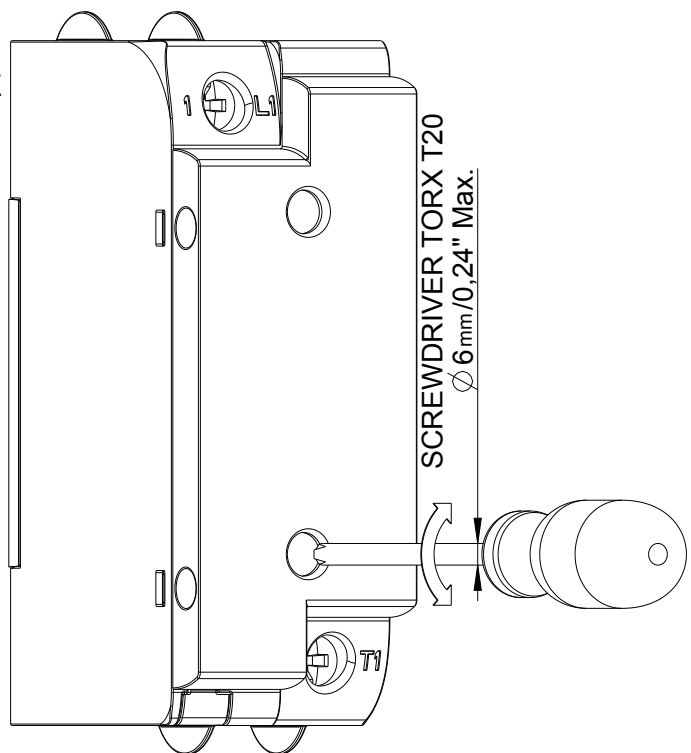
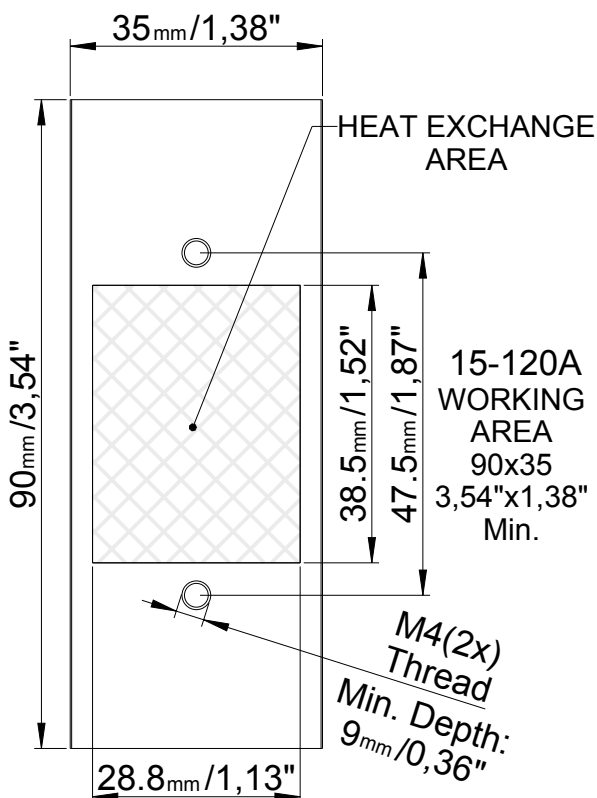

DIMENSIONS AND MOUNTING MEASUREMENTS

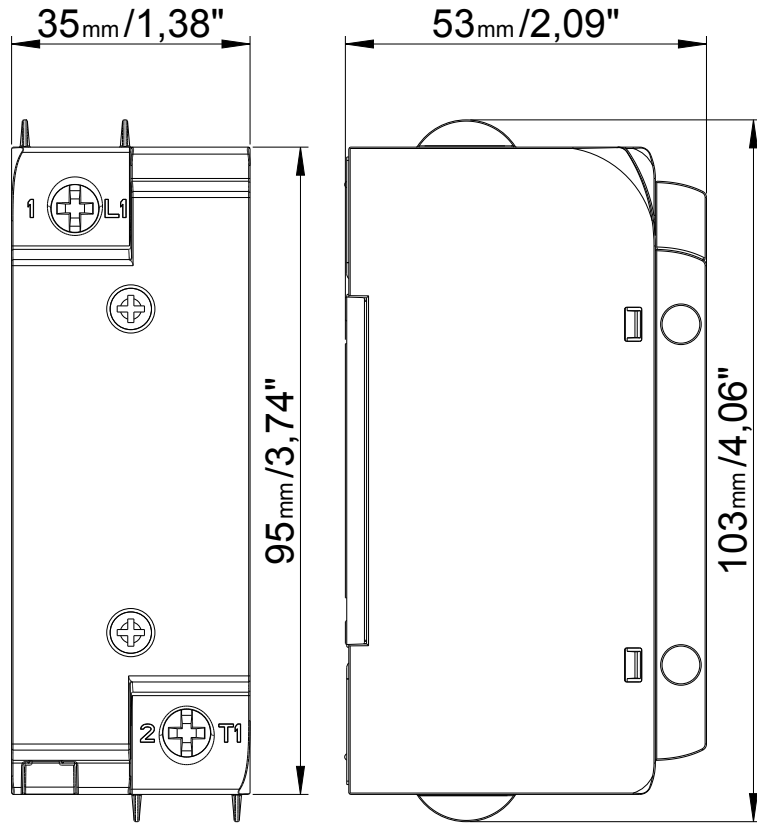

15-120A

FRONT VIEW



VERSION WITH ANALOGUE INPUT

Versione AN (Ingresso Analogico)
AN Version (Analogue Input)

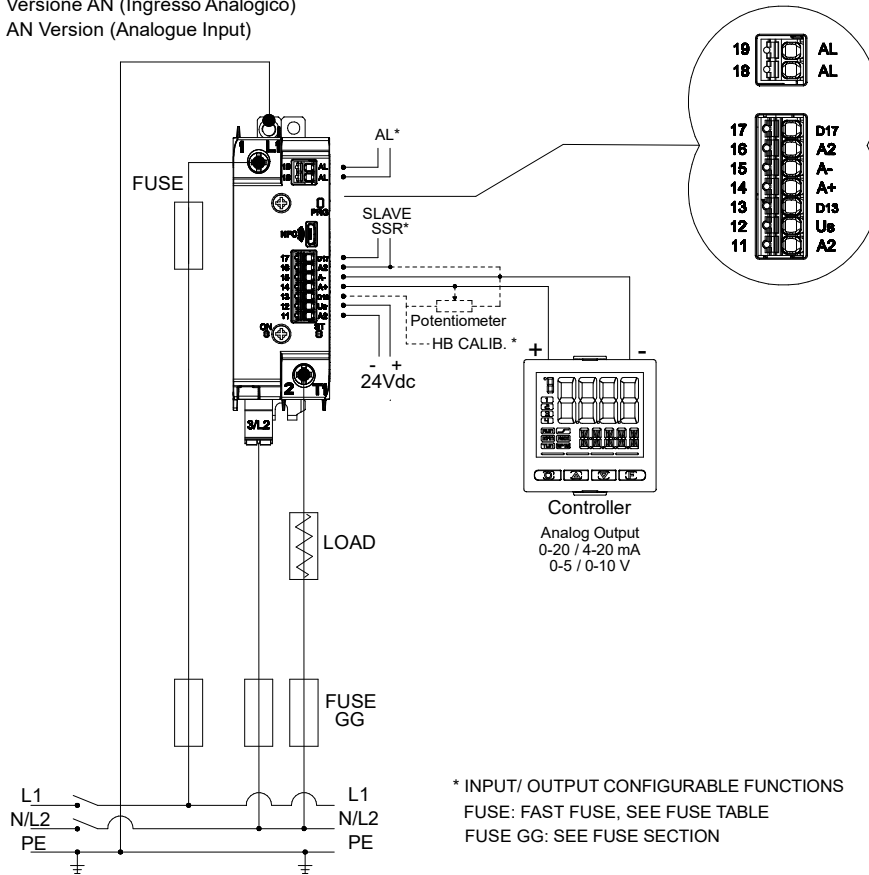

* INPUT/ OUTPUT CONFIGURABLE FUNCTIONS
FUSE: FAST FUSE, SEE FUSE TABLE
FUSE GG: SEE FUSE SECTION

COLLEGAMENTO PER CARICO MONONASE
CONNECTION FOR SINGLE PHASE LOAD

Power terminals		
Rif.	Description	Note
1/L1	Line Connection	
2/T1	Load Connection	
3/L2	Line voltage reference connection	
Power supply and AN version signal connector (analogue input)		
11/A2-	GND (-) with 24Vdc power supply	
12/Us	Signal (+) with 24Vdc power supply	GRM power supply: Range 12 - 30 Vdc, I _{max} 20mA @ 24Vdc With option FAN63 (Only 90/120A): Range 20 - 27 Vdc, I _{max} <150 mA a 24V with running fan
13/D13	Potentiometer power supply output (+ 5Vdc) / Auxiliary digital input 1 / PWM control input	Potentiometer output voltage: 5V DC, I _{out} max = 10mA Digital input: 5-30V max 3 mA PWM control input: 5-30V max 3 mA, Frequency range: (1, ..., 100 Hz), Resolution max 1% (0.1ms)
14/A+	Analogue differential command input	
15/A-		
16/A2-	GND alarm output	Same as 11/A2- connection
17/D17	Master-Slave output /Alarm output / Digital input auxiliary 2	Master-Slave output: Output voltage: Us - 0.7Vdc, I _{out} max = 15mA Alarm output: PNP output normally not active (Configurable as normally active) (Us*1,14) - 0.7Vdc (ver. AA), I _{out} max =15mA Digital input: 5-30V, max 3mA
18/AL		Dry contact N.O. Maximum current: 150mA Maximum voltage = 30 Vdc Closed contact impedance <1 Ω Open contact impedance > 1 MΩ
19/AL	Alarm output	

VERSION WITH IO-LINK INPUT

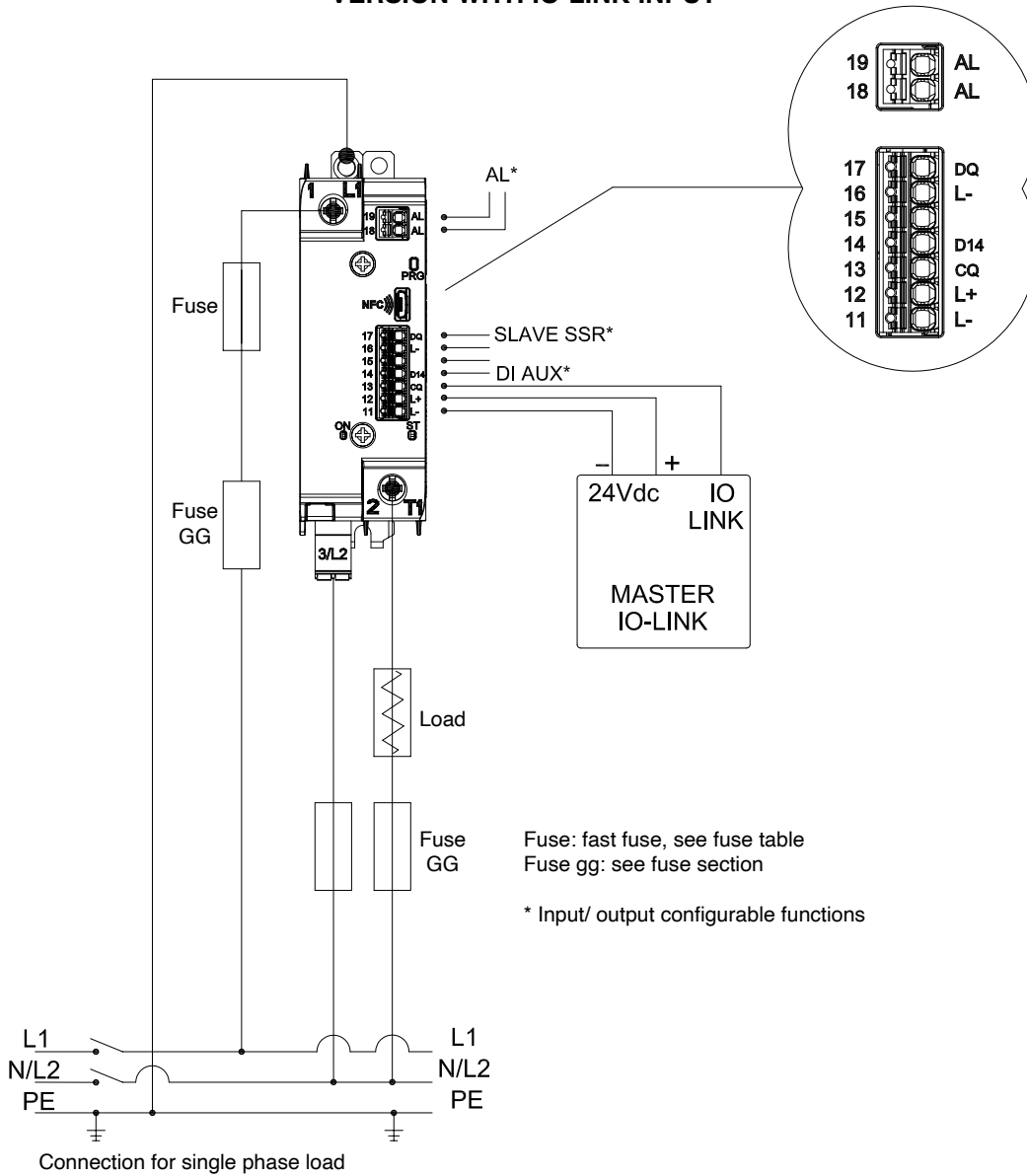

Power terminals			
Ref.	Description		Notes
1/L1	Line Connection		
2/T1	Load Connection		
3/L2	Line voltage reference connection		
I version signal connector (IO-LINK)			
11/L-	Power GND		
12/L+	+ V DC power supply		GRM power supply (Range from 10 to 30 V DC, I _{max} = 20 mA at 24V)
			GRM-H-90/120A-..FAN63: GRM-H + Fan power supply (Range from 20 to 27 V DC, I _{max} <150 mA at 24V with Fan active)
13/CQ	IO-LINK communication line		
14/D14	Auxiliary digital input 1		Digital input: 5-30Vdc, max 3mA
16/L-	GND alarm output (common to terminal 11/L-)		
17/DQ	Master-Slave output /Alarm output / Digital input auxiliary 2		Master-Slave output: Output voltage: U _s - 0.7Vdc, I _{out} max = 15mA Alarm output: PNP output normally not active (Configurable as normally active), output voltage: U _s - 0.7V DC , I _{out} max =15mA Digital input: 18-30Vdc, max 3mA
18/AL	Alarm output		Dry contact N.O. Maximum current: 150mA Maximum voltage = 30 Vdc Closed contact impedance <1 Ω Open contact impedance > 1 MΩ
19/AL			

ANALOG CONTROL WITH MR OPTION (MODBUS RTU)

Versione AN (Ingresso Analogico) con opzione MR (Modbus RTU)
 AN version (Analogue Input) with MR option (Modbus RTU)

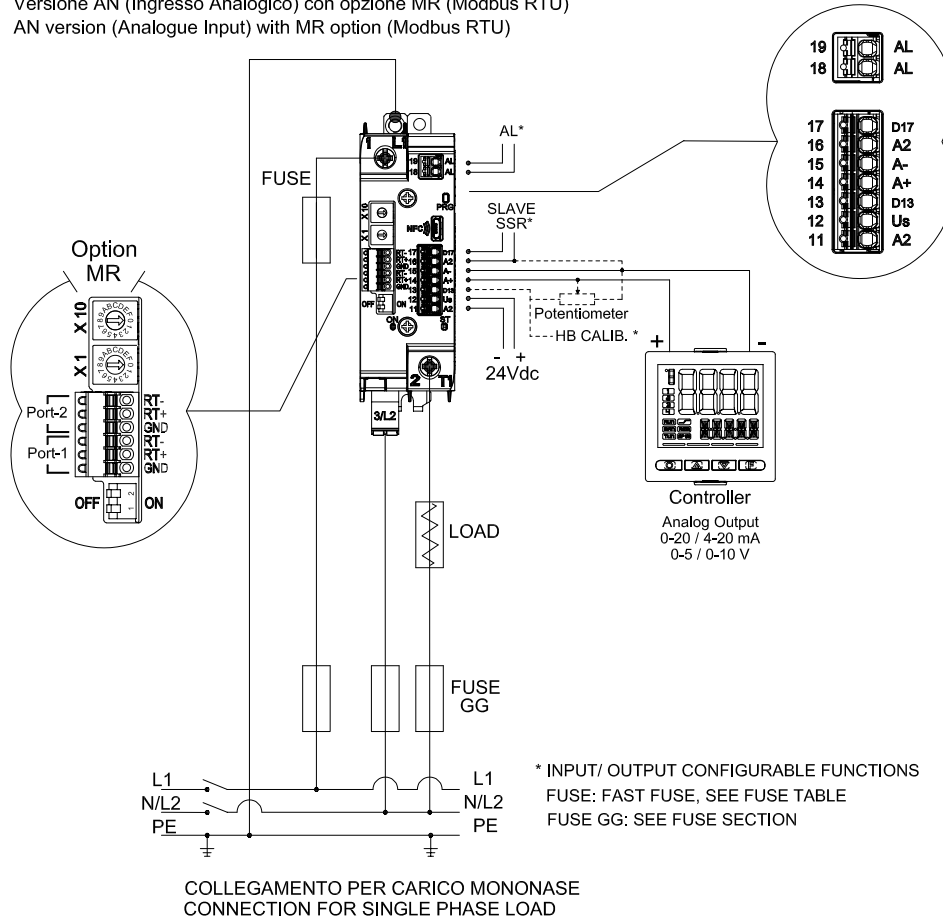

Power terminals		
Ref.	Description	Notes
1/L1	Line Connection	
2/T1	Load Connection	
3/L2	Line voltage reference connection	
Power supply and AN version signal connector (Analog Input)		
11/A2-	GND (-) with 24Vdc power supply	
12/Us	Signal (+) 24Vdc power supply	GRM power supply with MR option: Range 18 -30 Vdc, I _{max} 35mA @ 24Vdc
13/D13	Potentiometer power supply output (+ 5Vdc) / Auxiliary digital input 1 / PWM control input	Potentiometer output voltage: 5V DC, I _{out} max = 10mA Digital input: 5-30V max 3 mA PWM control input: 5-30V max 3 mA, Frequency range: (1, ..., 100 Hz), Resolution max 1% (0.1ms)
14/A+ 15/A-	Analogue differential command input	
16/A2-	GND alarm output	Same as 11/A2 connection
17/D17	Master-Slave output / Alarm output / Digital input auxiliary 2	Master-Slave output: Output voltage: Us - 0.7Vdc, I _{out} max = 15mA Alarm output: PNP output normally not active (Configurable as normally active) Output voltage: Us - 0.7V DC, I _{out} max = 15mA Digital input: 5-30V, max 3mA
18/AL 19/AL	Alarm output	Dry contact N.O. Maximum current: 150mA Maximum voltage = 30 Vdc Closed contact impedance < 1 Ω Open contact impedance > 1 MΩ
RS-485 fieldbus signal connector (only with MR option)		
RT-	Tx/Rx- (Data transmission B-)	Port-1 and Port-2 interconnected for multislave chain connections * GND signal connection between slaves is recommended
RT+	Tx/Rx+ (Data transmission A+)	
GND *	Serial line GND reference signal	
Rotary switch Modbus node address configuration (only with MR option)		
X10	Tens	Node address between 01 to 99
X1	Unit	
RS485 termination line configuration (only with MR option)		
OFF	Serial line termination not active	It is recommended to enable the termination for the last device connected to the serial line. ATTENTION: Both switch must be configured in the same position
ON	Serial line termination active	

TECHNICAL SPECIFICATIONS

INPUTS

Analogue command input (Versions with AN input type)

Function	Proportional power control signal
Maximum Error	1% f.s. \pm 1 scale point at an ambient temperature of 25°C / 77°F
Thermal shift	<100 ppm/° C on f.s.
Sampling time	10 ms
0-10V scale	Input impedance > 500 K Ω
0-5V scales	Input impedance > 500 K Ω
0-20mA or 4-20mA scale	Internal Shunt Resistance: 250 Ω
Potentiometer input	Potentiometer resistance: 1 K Ω at 47 K Ω Potentiometer power supply: + 5V (provided by GRM, max 10mA)
Linear input reading scale	0 ... 100.0 %
Common mode immunity	-60V, +60V

IO-LINK input (Versions with input type I)

Function	IO-LINK fieldbus communication line
Protocol	IO-LINK Type of transmission: COM2 (38.4 kBaud) IO-Link version: 1.1.2 SIO mode: Yes Auxiliary output: Pin 17/ 18-19 Alarm output Auxiliary input: Pin 14

Line voltage and load current measurement

Load current measurement function	Measurement range (full-scale f.s.): 0 ... 1.5 * I _{rated_product}
RMS current measurement accuracy	2% f.s. at room temperature of 25°C / 77°F Thermal shift: <200 ppm/° C
Line voltage measurement function	Working voltage range (full-scale f.s.): 60...660Vac
RMS voltage measurement accuracy	2% f.s. at room temperature of 25°C / 77°F Thermal shift: <100 ppm/° C
Current and voltage sampling time	10 ms
Line frequency	50/60 Hz

Configurable I/O

I/O pin 13 configurable (only with Analog version)

Function	Configurable as digital output or input
Output Function	Configurable alarm output functions (partial / total load break, line fault, thermal alarm) Potentiometer power supply 5V (max 10mA)
Output type	Output Type Digital output normally off (configurable as normally active). PNP type, output voltage: 5Vdc, I _{out} max = 10mA (not protected against short circuit)
Function Input (default)	Teach In HB partial breakage alarm threshold calibration (default), SCR logic control, Proportional control via PWM, On / Off Software, Reset alarms
Input voltage range	5-30V (max 3 mA)
Voltage reading status "0"	< 2 V
Voltage reading status "1"	> 5 V
Input impedance	17 K Ω
PWM input	Max frequency: (1, ..., 100 Hz) Max resolution 1% (0.1ms)

Configurable pin 14 input (only with IO-Link version)

Function	Configurable digital input
Function Input	Teach In HB partial breakage alarm threshold calibration, Feedback Calibration, On / Off Software, Reset alarms, Dry out start / restart, disabled (default).
Input voltage range	5-30V (max 3 mA)
Voltage reading status "0"	< 2 V
Voltage reading status "1"	> 5 V
Input impedance	17 K Ω

I/O pin 17 (D17 / DQ)

Function	Configurable as digital output or input
Function Output (default)	SSR output retransmission (default, for two-phase / three-phase slave control) Configurable alarm (partial / total load break, line fault, thermal alarm)
Output type	Output Type Digital output normally off (configurable as normally active). PNP type, output voltage: U _s (24Vdc)-0.7Vdc, I _{out} max = 30mA (not protected against short circuit)
Function Input	Teach In HB partial breakage alarm threshold calibration, SCR logic command, Software On / Off, Alarm reset
Input voltage range	5-30V (max 3 mA)

Voltage reading status "0"	< 2 V												
Voltage reading status "1"	> 5 V												
Input impedance	17 K Ω												
OUTPUTS													
Alarm output (pin 18 19)													
Function	Configurable alarm output (default): Partial load break, line fault, thermal alarm												
Type	Voltage free contact (solid state N.O.) max characteristics: 30V-150mA conduction resistance: $\leq 1\Omega$												
COMMUNICATIONS													
Porta microUSB di servizio													
Functions with TTL serial cable	Only for initial product configuration, via PC. Use a PC connected to the GRM, ONLY via the Gefran adapter cable. The adapter powers the GRM. Cod. F060800 (PC with USB).												
Type	Micro USB type B connector												
Insulation	TTL serial NOT isolated												
Funzione Dongle NFC:	Available for configuration, reading Product Information and diagnostic data. Use App downloadable from PlayStore and AppleStore and NFC Dongle (see accessories table)												
Modbus RS485 (Option)													
Function	Serial line communication												
Protocol	ModBus RTU												
Type	RS485												
Baudrate	Configurable 1200 ...115200bit/s (default 115,2Kbit/s)												
Node address	Configurable by two rotary switch (rotary-switches)												
Insulation	500V												
Parity	None/Odd/Even (default "none")												
StopBits	1												
DataBits	8												
POWER (STATIC GROUP)													
CATEGORY OF USE (Tab. 2 EN60947-4-3)	AC 51: resistive or low-inductance loads AC 55b: infrared lamps AC56a transformers, resistive loads with high temperature coefficient												
Trigger modes	OnOff - Zero crossing firing. FCT- Fixed Cycle Time - Zero Crossing with constant cycle time (settable in the range 1...200 sec). BF - Burst Firing with optimised minimum variable cycle time (Zero crossing firing). HSC - Half Single Cycle, corresponds to a Burst Firing which handles half on/off cycles (Zero crossing firing). PA - load management by adjusting the power-on phase angle. It is useful for reducing flicker with short-wave infrared loads. Softstart ramp in Phase Angle configurable with any configured Firing mode Delay triggering : First cycle start-up delay (only for ZC, BF, single phase control mode) Can be set from 0 ° to 90 °. It is useful for inductive loads (primary transformer) to avoid the current peak that could in some cases trigger the ultra-rapid fuses for the protection of SCRs.												
Feedback and Limit functions (optional)	Peak current or RMS limiting algorithms available. Feedback in current (I, I ²), voltage (V, V ²) or power.												
Max. rated voltage	480 V AC								600 V AC				
Working voltage range	60-530Vac								60-660Vac				
Non-repetitive voltage (Surge protection level)	1200 Vp								1400 Vp				
Rated frequency	50/60Hz with auto-determination												
Rated current	GRM Model												
	10	15	25	25I	30	30I	40	50	60	75	90	120	
	10A	15A	25A	25A	30A	30A	40A	50A	60A	75A	90A	120A	
Non-repetitive over-current, (t=20 msec)	620A	620A	620A	1600A	620A	1600A	620A	1600A	1600A	1600A	1500A	1500A	
I ² t for melting (t = 1... 10msec) A ² s	1800	1800	1800	12800	1800	12800	1800	12800	12800	12800	11250	11250	
critical dv/dt with output disabled	1000 V/ μ s												
Rated impulse withstand voltage	4kV												

Rated impulse withstand voltage	4kV
Rated current in short circuit condition	5kA
Minimum Load Current:	150 mA
Voltage drop over rated current:	= < 1,2Vrms
Presence of leakage current:	< 3mA (Maximum value with nominal Voltage and Junction temperature of 125°C / 257°F)
Dissipated power	Calculation of power dissipated by the solid state relay Pd [W] = 1,2 * Irms Irms = single-phase load current Example: load current = 20Arms, Dissipated thermal power: Pd = 20 * 1.2 = 24W
Heatsink Thermal Resistance Calculation	Rth[°C/W] = (90°C - max amb. T) / Pd where Pd = dissipated power Max. amb. T = max air temperature inside the electrical cabinet. Use a heatsink with thermal resistance inferior to the calculated one (Rth). Maximum surrounding air temperature 40°C "Open Type Equipment" suitable for use in pollution degree 2 or better. Example: Thermal power dissipated: Pd=20*1,2= 24 W T.amb.max = 40°C Rth = (90-40)/24=2,08[°C/W]
INTEGRATED DIAGNOSTICS	
Advanced Diagnostics	- Power failure for: SCR open / Load interrupted / No line voltage - Overheating alarm SCR short circuit (current presence with OFF command). HB (Heat Break) Alarm: - HB alarm load interrupted or partially interrupted, up to 8 loads in parallel. - Automatic calibration of the HB alarm threshold based on the current load level default, alarm threshold equal to 90% of the current read during calibration, recommended value for diagnosing a maximum of 5 equal loads in parallel). So, if the device is left at factory settings, it can manage 2, 3, 4 or 5 loads in parallel without reconfiguration. Note 1: with Digital command turn ON minimum time = 50 ms to detect broken load. Note 2: For the proper operation of the partial load break alarm even in the most critical conditions (8 equal loads in parallel), it is necessary that the total current of the load (not faulty) is at least 30% of the rated current of the GRM (on a GRM from 15A -> 4.5A) Example: a nominal size 15A GRM commands 8 equal resistors in parallel. To have an alarm of failure of only one of the 8 loads in parallel, the single load must have absorption of at least 0.56A, the total load must absorb at least 4.5A (0.56A * 8 loads).
GENERAL CHARACTERISTICS	
Power supply	12 - 30 Vdc I _{max} 20mA @ 24Vdc
Power supply with GRM-H-90/120A-.. FAN63 option	Power supply GRM-H + Fan (Range from 20 to 27 Vdc, I _{max} <150 mA to 24V with fan running)
Indications	2 leds: ON (Green LED): Control status SCR STATUS (RGB LED): State of operation
Protection rating	IP20
Working temperature	0...80°C (32 ... 176°F) (see derating curves)
Storage temperature	-20°C - +85°C (-4 ... 185°F) average temperature in a period of 24H not higher than 35°C (95°F) (according to EN 60947-4-3 § 7.1.1)
Maximum relative humidity	90% non-condensing
Environmental conditions of use	Indoor use, maximum altitude 2000m For higher altitudes consider: -Decreasing 1% of rated current for every 100m (328ft) above elevation 2000m (6562ft). -Decreasing of maximum voltage by correction factor: 0.88 from 2000 (6562ft) to 3000m (9842ft) 0.77 from 3001 (9846ft) to 4000m (13123ft) 0.68 from 4001 (13127ft) to 5000m (16404ft) Example for GRM-..25-60.. at 2800 mslm (9186ft) - 25A nominal derated by 1%*8-->23A - 600Vac nominal, maximum voltage 660Vac derated to 660*0.88=580.8Vac
Installation	DIN EN50022 bar or panel mount by screws

Installation	DIN EN50022 bar or panel mount by screws	
Installation requirements	Installation category II, pollution degree 2	
	Maximum air temperature around the device 40°C / 104°F (for Temperature > 40°C / 104°F see derating curves)	
Weight	GRM-H 10, 15, 25A, 25I	388 g / 16.69 Oz
	GRM-H 30A, 30I	388 g / 16.69 Oz
	GRM-H 40, 50A	388 g / 16.69 Oz
	GRM-H 60, 75A	688 g / 24.27 Oz
	GRM-H 90A	796 g / 28.09
	GRM-H 120A	796 g / 28.09
	GRM 10A ...120A	156 g / 5.50 Oz

PROTECTION FUSES

Type 1 and Type 2 coordination are ratings based on the level of protection and resilience provided during a high current fault. Device is designed to protect people and equipment during a short circuit fault, but the differences between the two levels can be explained as follows:

Type 1 : after a short circuit event it may be too damaged for further use.

Type 2 : after a short circuit event device will still be in working.

Protection co-ordination (Type 2)

Size device	Fuse nominal Current	Model and fuse size (manufacturer Bussmann Div Cooper (UK) Ltd)	Fuse code (descr.)	Fuse holder accessory code (descr.)
15	16	FWC-16A10F 10x38	338470 (FUS-016)	337132 (PF-10x38)
25,25I	25	FWC-25A10F 10x38	338474 (FUS-025)	
30,30I	32	FWC-32A10F 10x38	338483 (FUS-032)	
40	40	FWP-40A14F 14x51	338147 (FUS-040)	337131 (PF-14x51)
50	50	FWP-50A14F 14x51	338079 (FUS-051)	
60	63	FWP-63A22F 22x58	338191 (FUS-063)	337130 (PF-22x58)
75	80	FWP-80A22F 22x58	338199 (FUS-080)	
90	100	FWP100A22F 22x58	338478 (FUS-100)	
120	125	170M1418 000-TN/80	338106 (FUS-100)	337092 (PF-DIN)

Protection co-ordination (Type 1) according to UL 508

The devices are suitable For Use On A Circuit Capable Of Delivering Not More Than 100,000 A rms Symmetrical Amperes, 600 Volts Maximum when Protected by UL Listed fuses with size and class as specified in the table below:

Size device	Fuse Class	Fuse Current Max Size [A]	Prospective short circuit current [kArms]
15, 25 , 30	J	40	100
	CC	30	
40	J	40	
25I		80	
30I		80	
50		80	
60		80	
75		80	
90		125	
120		125	

Use Fuses Only.

GG FUSES

An electrical protection device known as a GG FUSE must be used to ensure protection against short-circuit of the electrical cable (see EN 60439-1, paragraph 7.5 Short-circuit protection and short-circuit withstand strength” and 7.6 “Switching devices and components installed in ASSEMBLIES”, or the equivalent paragraphs of standard EN 61439-1).

ACCESSOIRES

Code	Description
F089025	1 NFC dongle for configuration via App + 1 Gefran keychain lanyard
F089026	5 NFC dongles for configuration via App + 5 Gefran keychain lanyards
F089027	10 NFC dongles for configuration via App
F060800	Cable for programming with PC, USB-TTL 3 V with USB - microUSB connectors, length 1,8 m

PROTECTION WITH MCB

Protection co-ordination (Type 2) with Siemens Miniature Circuit Breaker (MCB / Thermal-Magnetic) 5SY4 series, curve A, 1P and 2P						
Current size model (I ² t)	1P MCB model (MCB Nominal current in A) at 230Vac *	Wire cross sectional area (mm ²)	Minimum length ***of copper wire conductor (m)	2P MCB model (MCB Nominal current in A) at 400Vac **	Wire cross sectional area (mm ²)	Minimum length*** of copper wire conductor (m)
GRM(-H)-10,15, 25, 30, 40 (1800 A2s)	5SY4110-5 (10)	1,0	6,0	5SY4210-5 (10)	1,0	6,0
		1,5	9,0		1,5	10,0
		2,5	14,0		2,5	14,0
	5SY4116-5 (16)	1,0	6,0	5SY4216-5 (16)	1,0	6,0
		1,5	9,0		1,5	10,0
		2,5	14,0		2,5	14,0
	5SY4120-5 (20)	4,0	15,0	5SY4220-5 (20)	4,0	25,0
		1,5	9,0		1,5	10,0
		2,5	15,0		2,5	21,0
	5SY4125-5 (25)	4,0	30,0	5SY4225-5 (25)	4,0	30,0
		2,5	18,0		2,5	18,0
	5SY4132-5 (32)	4,0	30,0	5SY4232-5 (32)	4,0	30,0
2,5		21,0	2,5		36,0	
	4,0	35,0		-	-	
For MCBs smaller than those indicated in the lines below, there are no section and length constraints						
GRM(-H)-25I, 30I, 50, 60, 75 (12800 A2s)	5SY4132-5 (32)	2,5	2,0	5SY4232-5 (32)	2,5	2,0
		4,0	4,0		4,0	4,0
		6,0	7,0		6,0	7,0
	5SY4140-5 (40)	4,0	4,0	5SY4240-5 (40)	4,0	4,0
		6,0	7,0		6,0	7,0
		10,0	10,0		10,0	10,0
	5SY4150-5 (50)	6,0	7,0	5SY4250-5 (50)	6,0	7,0
		10,0	10,0		10,0	10,0
	5SY4163-5 (63)	16,0	18,0	5SY4263-5 (63)	16,0	18,0
		6,0	7,0		6,0	7,0
		10,0	10,0		10,0	10,0
		16,0	18,0		16,0	18,0
For MCBs smaller than those indicated in the lines below, there are no section and length constraints						
GRM(-H)-90,120 (11250 A2s)	5SY4132-5 (32)	2,5	2,0	5SY4232-5 (32)	2,5	2,0
		4,0	4,0		4,0	4,0
		6,0	7,0		6,0	7,0
	5SY4140-5 (40)	4,0	4,0	5SY4240-5 (40)	4,0	4,0
		6,0	7,0		6,0	7,0
		10,0	10,0		10,0	10,0
	5SY4150-5 (50)	6,0	7,0	5SY4250-5 (50)	6,0	7,0
		10,0	10,0		10,0	10,0
	5SY4163-5 (63)	16,0	18,0	5SY4263-5 (63)	16,0	18,0
		6,0	7,0		6,0	7,0
		10,0	10,0		10,0	10,0
		16,0	18,0		16,0	18,0

* The sizing is valid for a 230Vac phase-neutral line with an assumed short-circuit current of 2,5KA

** The sizing is valid for a 400Vac phase-to-phase line with an assumed short-circuit current of 5KA

*** Between MCB and Load plus return path which goes back to the lines/neutral

The use of MCBs with a **nominal size smaller** than the smallest ones associated with a specific GRM in the table, is allowed without restrictions on the length and section of the cables.

For example, a 25I size GRM can be coupled to a 5SY4116-5 (16) MCB with any cable length or section.

Example, for a GRM-H-50- ..., with line voltage of 230Vac, controlled load of 45 A nominal, with a section of 6mm² of cable, an MCB 5SY4150-5 (50 A) the minimum length of the cables is 7m (cable length is intended between MCB and load, including return).

EMC STANDARDS

EMC emissions

AC semiconductor motor controllers and conductors for non-motor loads	EN 60947-4-3	Class A Group 2
Emission enclosure CI compliant in firing mode single cycle and phase angle if external filter fitted	EN 60947-4-3 CISPR-11 EN 55011	

EMC Immunity

Generic standards, immunity standard for industrial environments	EN 60947-4-3	
ESD immunity	EN 61000-4-2	4 kV contact discharge 8 kV air discharge
RF interference immunity	EN 61000-4-3 /A1	10 V/m amplitude modulated 80 MHz-1 GHz 10 V/m amplitude modulated 1.4 GHz-2 GHz
Conducted disturbance immunity	EN 61000-4-6	10 V/m amplitude modulated 0.15 MHz-80 MHz
Burst immunity	EN 61000-4-4	2 kV power line 2 kV I/O signal line
Surge immunity	EN 61000-4-4/5	Power line-line 1 kV Power line-earth 2 kV Signal line-earth 2 kV Signal line-line 1 kV
Magnetic fields immunity	Test are not required. Immunity is demonstrated by the successfully completion of the operating capability test	
Voltage dips, short interruptions and voltage immunity tests	EN 61000-4-11	100%U, 70%U, 40%U

LVD safety

Safety requirements for electrical equipment for measurement, control and laboratory use	EN 61010-1
--	------------

CAUTION

This product has been designed for class A equipment. Its use in a domestic environment may cause radio interference, in which case the user may be required to use additional attenuation methods.

EMC filters are required in PA operating mode (Phase Angle, i.e., SCR triggering with a modulated phase angle). The filter model and current size depend on the configuration and the load used. It is important that the power filter is connected as close as possible to the GRM(-H).

ORDER CODE

GRM - A - B - C - D - E - F - G - H - I

Rated current	
10Aac High Accuracy	10
15Aac	15
25Aac	25
25Aac I2t++	25I
30Aac	30
30Aac I2t++	30I
40Aac	40
50Aac	50
60Aac	60
75Aac	75
90Aac (Fan needed)	90
120Aac (Fan needed)	120

Rated voltage	
480Vac (60Vac...530Vac)	48
600Vac (60Vac...660vac)	60

Control type	
Analogue (0..10V,4..20mA, PWM, Logic OnOff)	AN
IO-Link	I

Control Options	
Open Loop	OL
Advanced Control (Current limit/ DryOut)	AC
AC + Feedback (V,I,V ² ,I ² ,P,Z)	FB

(*) Not available with IO-link control type option

NOTE:

Advanced Diagnostic always included: Thermal protection, Thermal Alarm, Total and Partial heater break, No-line, Current reading.

0	
---	--



NFC Dongle accessory	
0	Absent
1	NFC Dongle included in the packaging

Options	
0	None
MR	Modbus RTU RS485 (*)

0	
---	--

0	
---	--

CE Conformity Declaration is available on web site www.gefran.com

	This device conforms to European Union Directive 2014/30/EU and 2014/35/EU as amended with reference to generic standards: EN 61000-6-2 (immunity in industrial environment) EN 61000-6-4 (emission in industrial environment) - EN 61010-1 (safety regulations).
	Conformity UL508 - File: E243386
	Short Circuit Current Rating 100KA / 600V according to UL 508

