

MAIN APPLICATIONS

- Extrusion, injection, blow moulding, thermoforming of plastics
- Vulcanization of rubber
- Synthetic fibre production and polymerisation
- Packing and packaging
- Dryers for ceramics and building elements
- Industrial electric ovens
- Food processing plants
- Chemical and pharmaceutical industry



MAIN FEATURES

- Wide current range from 10A to 75A per phase
- Ultra-compact size
- 2 Leg to reduce the heat generated
- Thermal protection always present
- Input command from logic signal Vdc/ Vac
- Leds signaling
- Cage terminals for power cables
- Load voltage 480V, 600Vac
- Thermal alarm and load fault option with LED and alarm output
- Internal overvoltage protections
- Switching at Zero Crossing of Voltage
- Compact versions with increased I²t
- Push-in connectors for command signals

PROFILE

Correct management of electrical heating elements for industrial heating applications

requires robust, safe, interference-free, fast and diagnostically capable static contactors.

The range of static contactors with GRZ heatsink meets all these requirements, with current ratings from 10 to 75 Amperes for single phase and voltages up to 600 V AC, with extremely compact size in every single current level.

GRZ COMMAND SIGNAL CONNECTION

The GRZ-H series can be controlled by DC and AC logical signals managed through push-in connectors for a faster and easier connection, even without tools.

The ON / OFF status of the static device is always displayed by a green LED on the front panel, for an immediate view of its operation.

POWER CONNECTIONS

Both the line voltage terminals available on the upper part of the device and the load terminals on the lower part are of the "cage" type, which offer the best and safest seal even for cables of different cross-sections,

whether mounted with a cable lug or simply stripped.

DIAGNOSTICS AND ALARMS

It is increasingly vital for operators and maintainers to recognize possible anomalies in the system immediately and solve them quickly in order to ensure the efficiency and profitability of machinery and plants. The GRZ series offers a series of diagnostic information associated with a physical alarm output with voltage-free or PNP-type isolated contact.

The thermal alarm is triggered if heat dissipation exceeds a critical threshold, signalling it with a yellow led on the front panel, interrupting the power supply and triggering the alarm output. Alarm functions are available for all sizes as an option.

The absence of current on the load or line voltage is signaled by a red LED on the front and by the activation of the alarm output.

The absence of current is verified for each single phase, it is therefore possible to detect even a partial failure of one of the three load parts (check the models and conditions of use).

Alarm output status is memorized: in the presence of a 24 V DC auxiliary power supply, the alarm will be memorized even in the event of an OFF

command.

The alarm is reset when normal operating conditions are restored, or when the 24 V DC auxiliary power supply is switched off and on again.

DIMENSIONS MEASUREMENTS

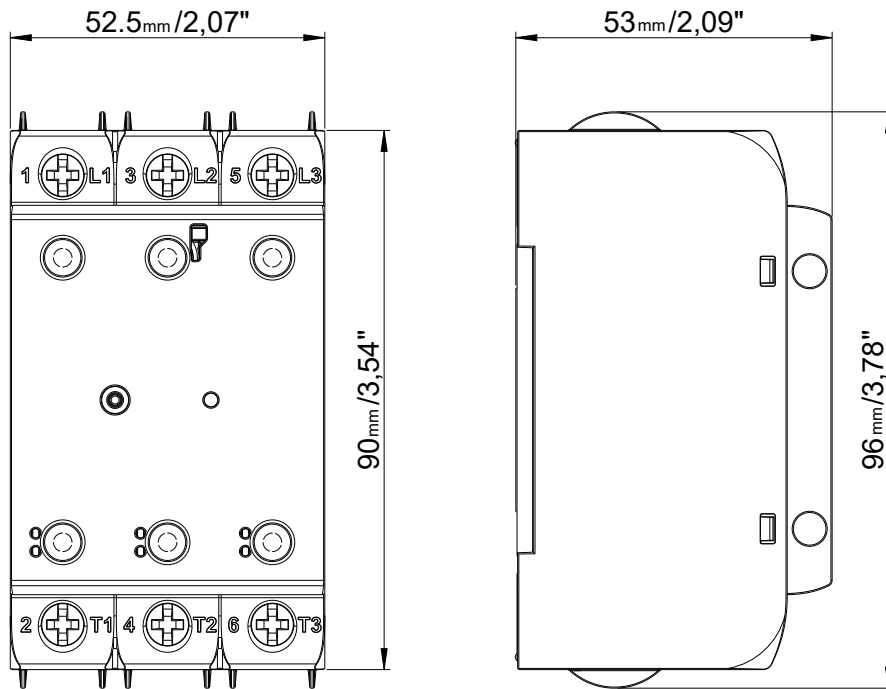

FIXING TO THE HEATSINK

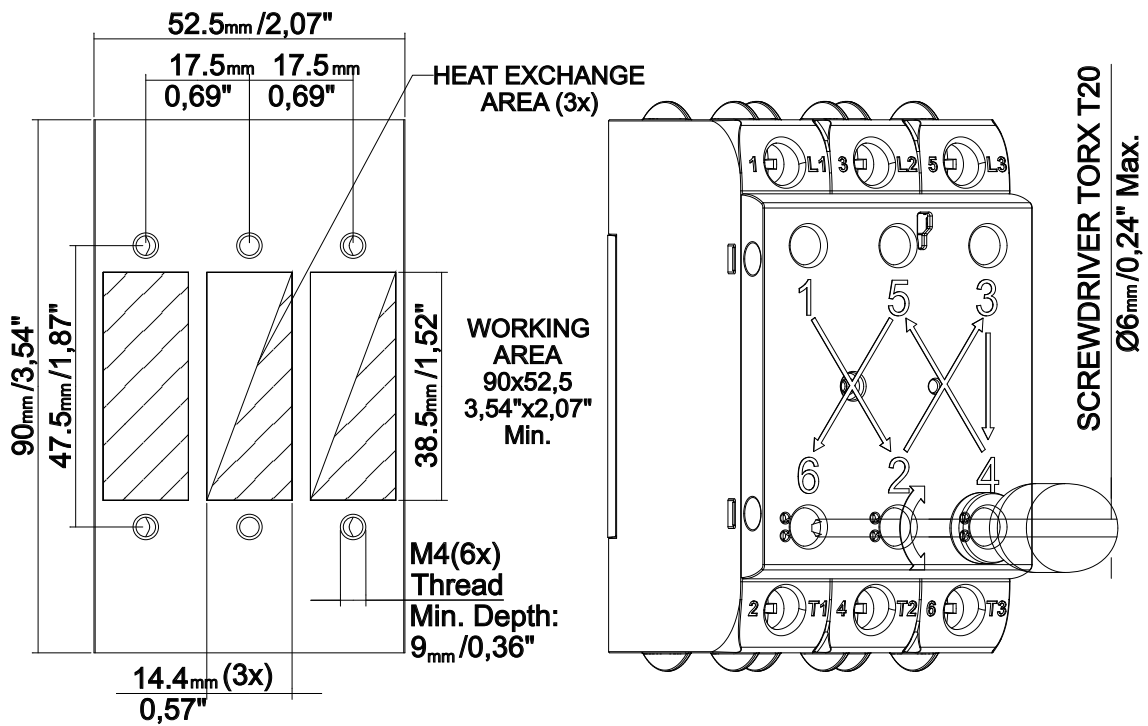

INSTALLATION

Use the extra-rapid fuse shown in the catalogue according to the connection example supplied.

Applications with uninterruptible power supply units must also include a safety circuit breaker for disconnecting the power line from the load. To obtain high device reliability, it is essential to install it correctly inside the panel in order to obtain adequate heat exchange between the heat sink and the surrounding air under conditions of natural convection.

Mount the device vertically (maximum 10° inclination from the vertical axis). Make sure that the cable ducts do not reduce these distances; in this case, mount the units overhanging the panel, so that the air can flow vertically on the heat sink without hindrance.

Minimum mounting distance

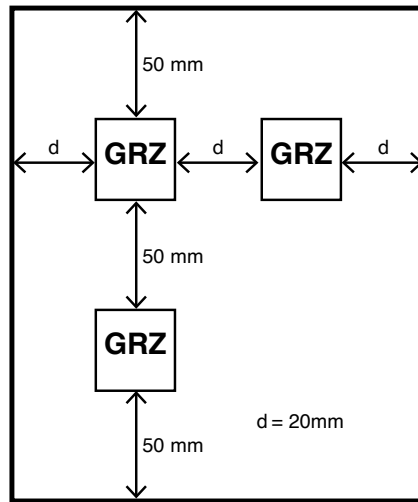

Limitations of use

- Ambient temperature limits, depending on derating curves.
- Need for air exchange with the outside or an air conditioner to transfer the dissipated power to the outside of the panel.
- Installation limits (distances between devices to ensure dissipation under natural convection conditions)
- Maximum voltage limits and derivative of the transients present on the line, for which the static unit provides internal protection devices (depending on the models).
- Presence of leakage current < 3mA (max. value with nominal voltage and junction temperature of 125°C / 257°F).

MOUNTING PROCEDURE ON THE HEATSINK

The module-heat sink contact surface must have a maximum flatness error of 0.05mm and a maximum roughness of 0.02mm. The anchorage holes on the heat sink must be threaded and countersunk. Caution: Spread 1 gram of heat conducting silicone paste (DOW CORNING 340 Heat Sink is recommended) on each dissipative metal surface of the modules. The surfaces must be clean, and there must be no impurities in the heat-conducting paste. Tighten the fixing screws as in figure until a torque of 0,30 Nm / 2,65 lb.in for M4 screws is reached. Wait 30 minutes so that the excess paste can drain away. Repeat the operation until a torque of 1,3 Nm / 11,5 lb.in for M4 screws.

SOLID STATE RELAY DISSIPATED POWER CALCULATION

Single-phase relay $P_d = 1.2 \cdot I_{RMS} [W] \cdot n$

I_{RMS} = single-phase load current
 n = number of controlled phases, 2 for 2S models, 3 for 3S models

HEAT SINK THERMAL RESISTANCE CALCULATION

$R_{th} [^{\circ}C/W] = (90^{\circ}C - \text{max. amb. } T) / P_d$
where P_d = dissipated power
Max. amb. T = max air temperature inside the electrical cabinet. Use a heat sink with thermal resistance inferior to the calculated one (R_{th}). Maximum surrounding air temperature 40°C "Open Type Equipment" suitable for use in pollution degree 2 or better.

**Command D without diagnostic option
(GRZ...D-0)**

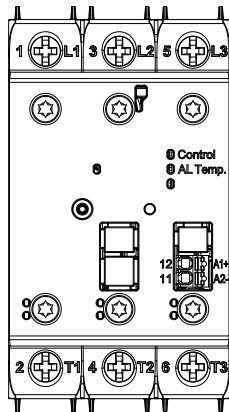

D-0

1/L1, 2/L2, 3/L3	Mains power line connections
2/T1, 4/T2, 6/T3	Load connections
11/A2-	Ground On/Off Control signal
12/A1+	Positive On/Off signal command Vdc
13/A2-	Ground (common with 11/A2-)
14/AL+	Alarm output (D-3 version; PNP output)
13 14	Alarm output (D-1,D-2 version; NO,NC contacts)
15/A2-	Ground (common with 11/A2-)
16/Us	Power supply, positiv signal
Control (Green led)	Status of the command signal
AI Fault (Red led)	Power Fault alarms (No Voltage, No current)
AI Temp. (Yellow led)	Over-temperature status

**Command D with diagnostic option
(GRZ...D-1/2/3)**

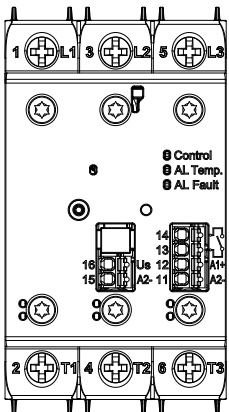

D-1

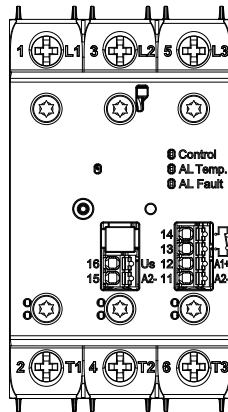

D-2

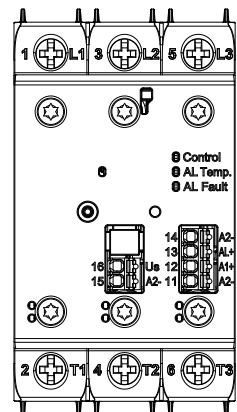

D-3

**Command A without diagnostic option
(GRZ...A-0)**

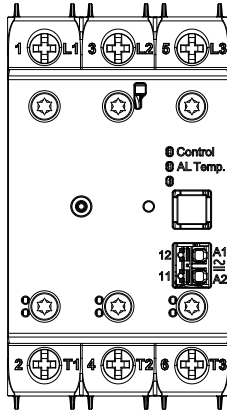

A-0

1/L1 , 2/L2 , 3/L3	Mains power line connections
2/T1 , 4/T2 , 6/T3	Load connections
11/A2 ~	On/Off signal command Vac
12/A1~	On/Off signal command Vac
13 14	Alarm output
Control (Green led)	Status of the command signal
Al Fault (Red led)	Power Fault alarms (No Voltage, No current)
Al Temp. (Yellow led)	Over-temperature status

**Command A with diagnostic option
(GRZ...A-2)**

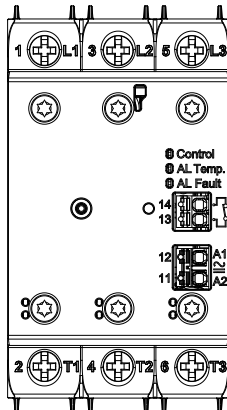

A-2

COMAND INPUT

Control Type	Type D		Type A
Pin	11/A2- , 12/A1+		11/A2 , 12/A1~
Diagnostic options	D-0	D-1/2/3	A-0/2
Control voltage	4,9V...32Vdc	3...32Vdc	20...260 Vac/Vdc
Max. command absorption	< 15mA @32V	<5mA @32V	< 8 mAac/dc @260 Vac/Vdc
Maximum reverse voltage	36Vdc	36Vdc	-
Voltage of guaranteed ON	≥4,9Vdc	≥ 3Vdc	≥ 15Vac/Vdc
Voltage of guaranteed OFF	≤4,3Vdc	≤ 1,8Vdc	≤ 6Vac/
Impedance input	500 kΩ	7,26 kΩ	-

ALARM OUTPUT (Diagnostics option)

Function	No Voltage OR No Current OR Overtemperature			
Command+Diagnostics option	D-1	D-2	D-3	A-2
Pin	13,14	13,14	13/A2-, 14/AL+	13,14
Output Type	Contact	Contact	PNP	Contact
State	Normally open (NO)	Normally Close (NC)	Normally Inactive (NO)	Normally Close (NC)
Rated voltage	30Vdc/25Vac	30Vdc/25Vac	Us - 0.7Vdc	30Vdc/25Vac
Conduction impedance	≤ 1Ω	≤ 15Ω	-	≤10hm
Maximum current	150mA	50mA	lout max. = 15mA	150mA
Maximum alarm intervention delay	< 400ms			
OR combination of multiple alarm signals	A single alarm signal equivalent to the logical OR of alarms of multiple GRZ devices can be obtained. Connect the alarm outputs (pins 13 and 14) in parallel (in the case of diagnostic option «1» and «3», NO) or in series (in the case of option «2», NC).			

TECHNICAL SPECIFICATIONS

POWER OUTPUT		
Controlled phases	3 controlled phases in the 3S version 2 controlled phases and one passing trough in the 2S version	
Category of use (Tab. 2 EN60947-4-3)	AC 51: resistive or low-inductance loads	
Trigger modes	Zero crossing	
Activation time	1/2 cycle	
Deactivation time	1/2 cycle	
Potential drop at rated current	< 1,2Vrms	
Power factor	1	
Rated working voltage	480 Vac	600 Vac
Working voltage range	24...530Vac	24 ... 660Vac
Non-repetitive voltage (Surge protection level)	1200 Vp	1400 Vp
Switching voltage for zero	< 20V	
Rated frequency	50/60 Hz	
critical dv/dt with output disabled	1000 V/μs	
Nominal insulation voltage input/output	4kVac rms for 1 minut	
Rated current in short circuit condition	5kA	
Minimum load current	150 mA	
Potential drop at rated current	= < 1,2Vrms	
Presence of leakage current	< 3mA (Maximun value with nominal Voltage and Junction temperature of 125°C / 257°F).	
Calculation of power dissipation	Pd = 1,2 * Irms[W]*n Irms = single-phase load current. n=number of controlled phases, 2 for 2S models, 3 for 3S models	
Heatsink Thermal Resistance Calculation	<p>Rth[°C/W] = (90°C - max amb. T) / Pd where Pd = dissipated power Max. amb. T = max air temperature inside the electrical cabinet. Use a heatsink with thermal resistance inferior to the calculated one (Rth). Maximum surrounding air temperature 40°C "Open Type Equipment" suitable for use in pollution degree 2 or better.</p> <p>Example : Thermal power dissipation: Pd=20*1,2= 24 W T.amb.max = 40°C Rth = (90-40)/24=2,08[°C/W]</p>	
Thermal protection	<p>The temperature of the SCR module is constantly monitored inside the device. When the maximum temperature threshold of the internal SCR is exceeded, current conduction to the load is interrupted and the yellow thermal protection LED comes on to signal the condition.</p>	

Model	Nominal current (@40°C) for each phase[A]	Non-repetitive overcurrent (t=20msec) [A]	I2t for blowout (t=1...10msec) [A2s]	Dimensions [mm]		
				Width	Height	Depth
2S						
15	15	620	1800	52,5	90	53
25	25	620	1800			
25I	25	1600	12800			
30	30	620	1800			
30I	30	1600	12800			
40	40	620	1800			
40I	40	1600	12800			
50	50	1600	12800			
75	75	1600	12800			
3S						
10	10	620	1800	52,5	90	53
20	20	620	1800			
20I	20	1600	12800			
25	25	620	1800			
25I	25	1600	12800			
30I	30	1600	12800			
40	40	620	1800			
40I	40	1600	12800			
65	65	1600	12800			

GENERAL CHARACTERISTICS	
Protection rating	IP20
Working temperature	0...70°C (32 ... 158°F) (see derating curves)
Storage temperature	-20°C - +85°C (-4 ... 185°F) average temperature in a period of 24H not higher than 35°C (95°F)(according to EN 60947-4-3 § 7.1.1)
Maximum relative humidity	90% non-condensing at 40°C
Environmental conditions of use	Indoor use, maximum altitude 2000m For higher altitudes consider: - Derating of 1% of the rated current every 100m above 2000m altitude. - Derating of the maximum voltage by correction factor: 0.88 from 2000 to 3000m 0.77 from 3001 to 4000m 0.68 from 4001 to 5000m Example for GRZ-..25-60.. at 2800 masl - 25A nominal derated by 1%*8-->23A - 600Vac nominal, maximum voltage 660Vac derated to 660*0,88=580,8Vac.
Installation	DIN EN50022 bar or panel mount by screws
Installation requirements	Installation category II, pollution degree 2 Maximum air temperature around the device 40°C / 104°F (for Temperature >40°C / 104°F see derating curves)
Weight	GRZ 10 - 75 210 g / 7,41 Oz

Logic voltage output command

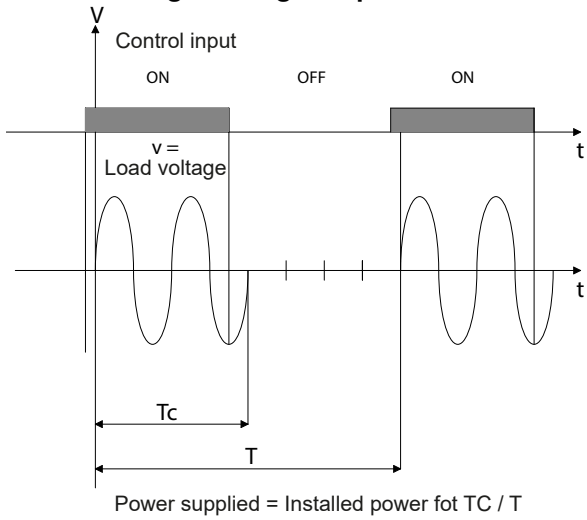

OVER TEMPERATURE PROTECTION

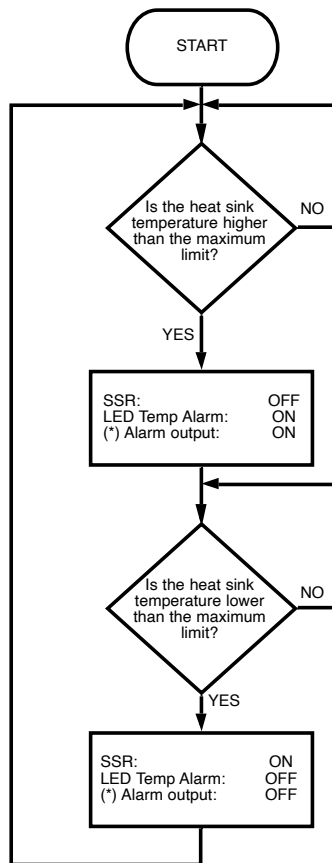

(*) Turned on alarm output only in case of versions with on-board diagnostic options (D-1/2/3 and A-2) on pins 14 and 15.

ALARMS

	Starting	OK	No voltage	OK	NO Current	OK	Over Temperature	OK									
	Device off, Voltage Line Off	Device off, Voltage Line On	Device on, Voltage Line Off	Load connected, Voltage Line On, active cmd	Line loss with active cmd	Loss 2 lines, with active cmd	Loss 3 lines, with active cmd	Line loss without cmd, retentive alarm	Ripristino condizione linea	Faulty load, Line On, activea control	Two-phase power failure	Total breakage	Total breakage, no command, retentive alarm	Reset alarm condition no current	Internal overtemperature, active control blocked	Retentive thermal alarm	Temperature reset
			(*1)		(*1)			(*3)		(⁻¹ / ₂)	(*2)	(*2)	(*3)				
LINE / LOAD / TEMP. STATUS																	
Voltage Supply L1 / T1	Active	Active	Active	Active	Active	Active	Active	Active	Active	Active	Active	Active	Active	Active	Active	Active	Active
Voltage Supply L2 / T2	Active	Active	Active	Active	Active	Active	Active	Active	Active	Active	Active	Active	Active	Active	Active	Active	Active
Voltage Supply L3 / T3	Active	Active	Active	Active	Active	Active	Active	Active	Active	Active	Active	Active	Active	Active	Active	Active	Active
Current L1 / T1	Not active	Active	Active	Active	Active	Active	Active	Active	Active	Active	Active	Active	Active	Active	Active	Active	Active
Current L2 / T2	Not active	Active	Active	Active	Active	Active	Active	Active	Active	Active	Active	Active	Active	Active	Active	Active	Active
Current L3 / T3	Not active	Active	Active	Active	Active	Active	Active	Active	Active	Active	Active	Active	Active	Active	Active	Active	Active
Over-temperature status	Not active	Not active	Not active	Not active	Not active	Not active	Not active	Not active	Not active	Not active	Not active	Not active	Not active	Not active	Active	Active	Not active
INPUTS STATUS																	
Power supply (pin 15/A2-, 16/Us)	Not active	Active	Active	Active	Active	Active	Active	Active	Active	Active	Active	Active	Active	Active	Active	Active	Active
Control command (pin 11/A2, 12/A1)	Not active	Active	Active	Active	Active	Active	Active	Active	Active	Active	Active	Active	Active	Active	Active	Active	Active
ALARMS OUTPUTS																	
Alarm Output (pin 13,14) NO	Not active	Not active	Active	Active	Active	Active	Active	Active	Active	Active	Active	Active	Active	Active	Active	Active	Active
Alarm Output (pin 13,14) NC	Active	Active	Active	Active	Active	Active	Active	Active	Active	Active	Active	Active	Active	Active	Active	Active	Active
LEDS STATUS																	
Control (Green led): Status of the command signal	Not active	Active	Active	Active	Active	Active	Active	Active	Active	Active	Active	Active	Active	Active	Active	Active	Active
Al Fault (Red led): Power Fault alarms (No Voltage, No current)	Not active	Not active	Active	Active	Active	Active	Active	Active	Active	Active	Active	Active	Active	Active	Active	Active	Active
Al Temp. (Yellow led): Over-temperature status	Not active	Not active	Not active	Not active	Not active	Not active	Not active	Not active	Not active	Not active	Not active	Not active	Not active	Not active	Active	Active	Not active

Legend

- Active
- Not active
- Any state is irrelevant

(*1) The GRZ..2S models detect the current or voltage fault only on the 2 controlled phases (L2/T2, L3/T3). GRZ..3S detects the faults on all three (L1/T1, L2/T2, L3/T3).

(*2) Each GRZ(-H) controlled phase is able to monitor the presence of current. In the case of star connection (with or without neutral) or open delta, it is sufficient for one of the 3 load branches to fail to detect total absence of current. For close delta type loads, it is necessary that at least two sides of the delta are faulty in order to detect the total absence of current on at least one branch.

(*3) Only for D-1/2/3 versions (which needs power supply) the alarm is kept active even in conditions in which there is no command signal. For the A-2 versions (which do not have a power supply) the alarms are managed only with the command active.

(*4) When the internal overtemperature condition is detected, the device goes into protection condition and does not actuate the command, avoiding further overheating

(*5) In alarm conditions, the green Control LED goes off, even in the presence of an active command.

CONNECTION EXAMPLES

Three-phase Triangle or Star connection without neutral on Three phases - GRZ with V DC or AC command input ("D" or "A" type input)
Valid for 2S (3PH, 2 controlled 1 pass through) models and for 3S (3PH, 3 controlled) models

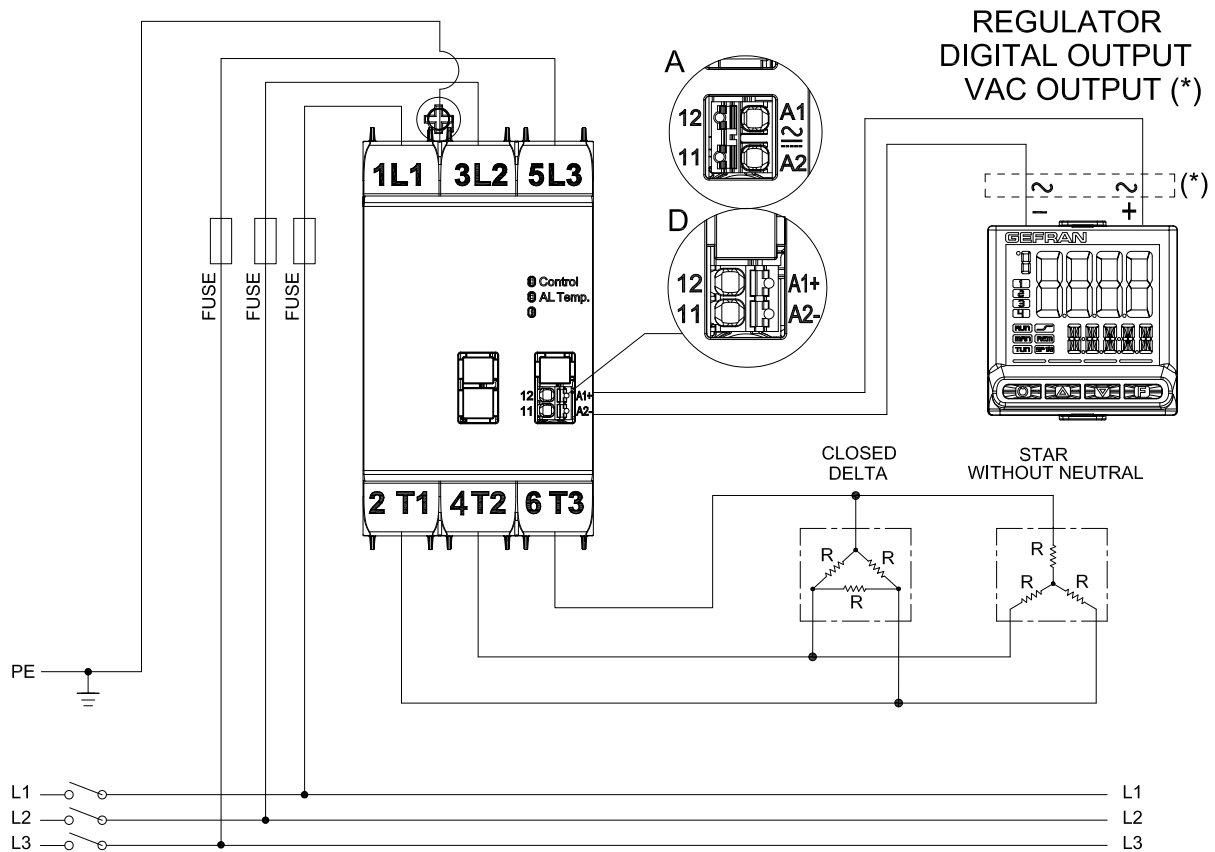

Three-phase Wye connection with neutral - GRZ with V DC or AC command input ("D" or "A" type input).
Valid **ONLY** for models 3S (3PH, 3 controlled) models.
NOT FOR GRZ 2S type (3ph, 2 leg controlled and 1 pass through)

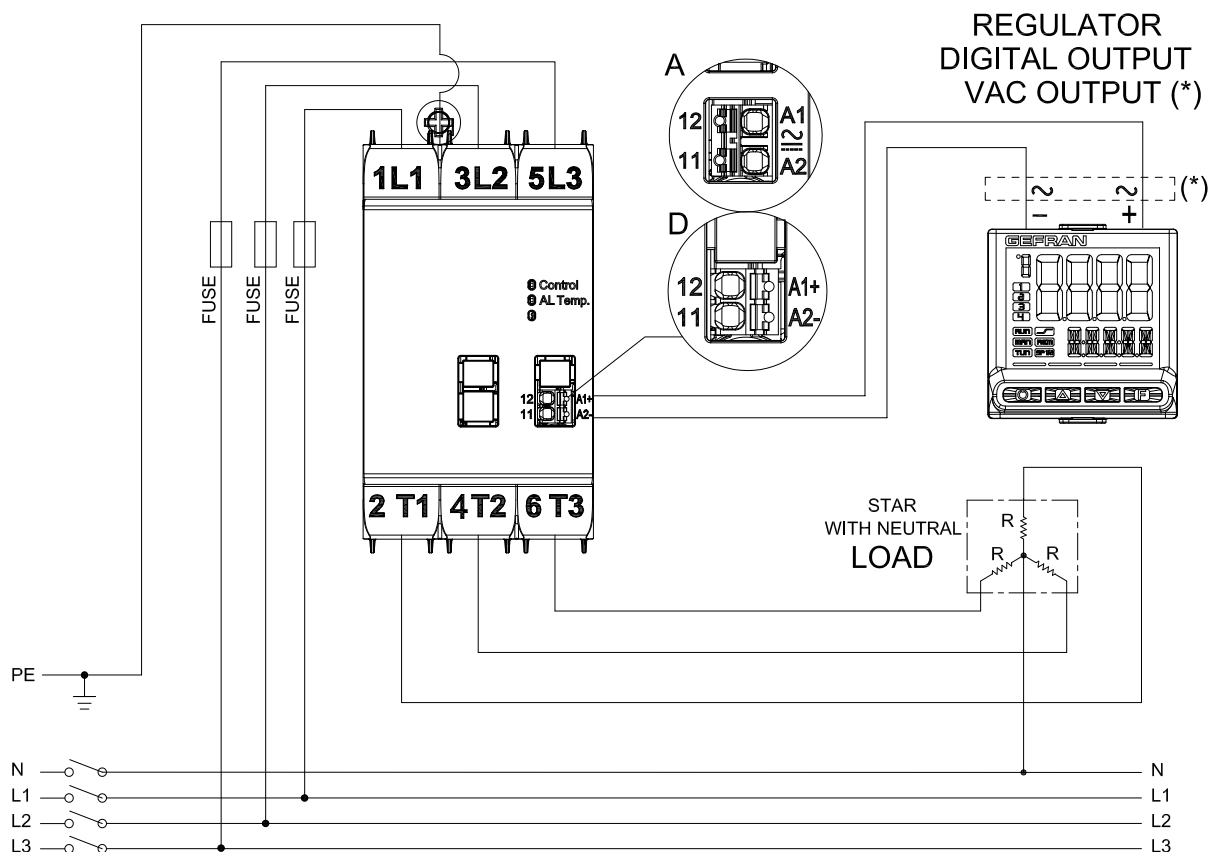

CONNECTION EXAMPLES

Open Delta connection with neutral - GRZ with V DC or AC command input ("D" or "A" type input).

Valid **ONLY** for models 3S (3PH, 3 controlled) models.

NOT FOR GRZ 2S type (3ph, 2 leg controlled and 1 pass through)

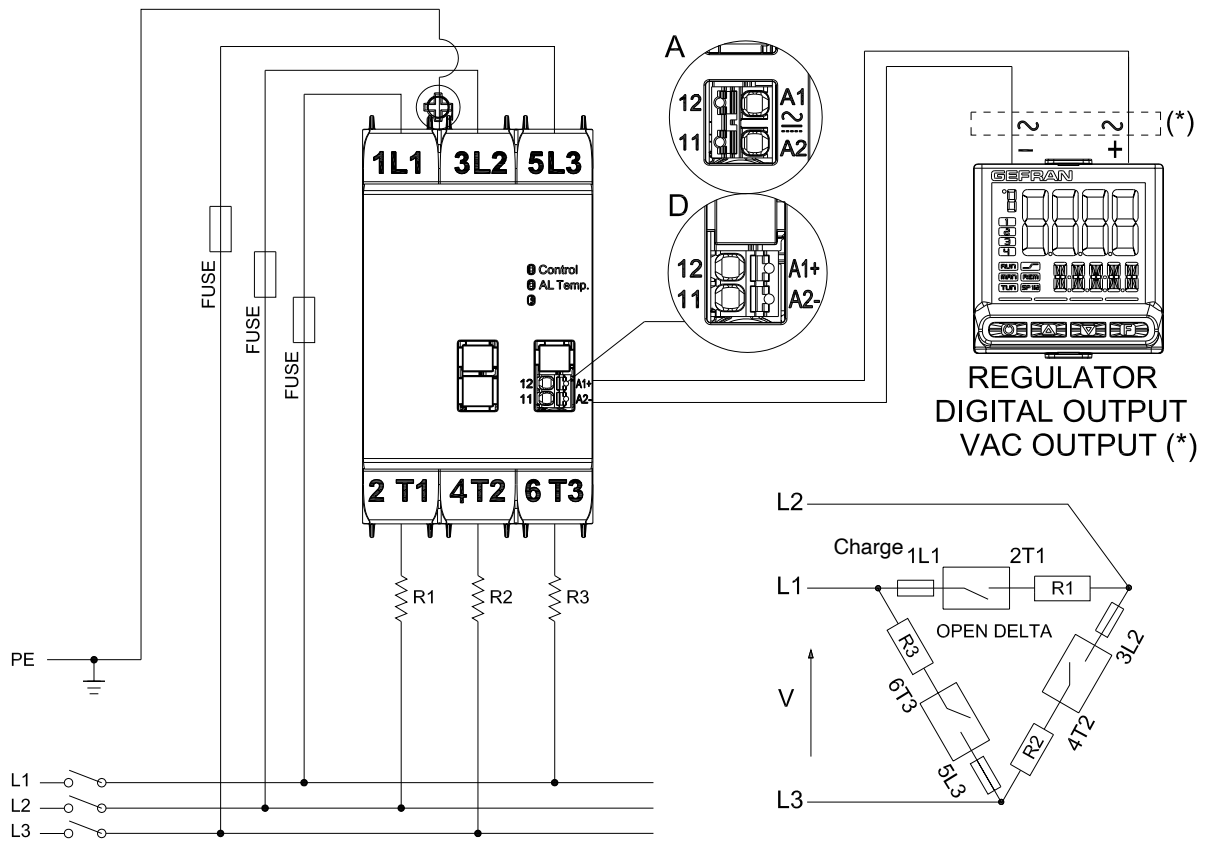

TABLE OF TERMINALS AND CONDUCTORS

POWER TERMINALS							
Rated load current	10/15A	20/25A	30A	40A	50A	60/65A	75A
Contact area (WxD) screw type	9,2 x 8 mm M5						
Stripping length	11 mm						
1 Conductor section 2 Conductors section (minimum section)	1 x 2.5 mm ² / 2 x 1.5 mm ²	1 x 6 mm ² / 2 x 4 mm ²	1 x 10 mm ² / 2 x 6 mm ²	1 x 16 mm ² / 2 x 10 mm ²	1 x 25 mm ² / 2 x 16 mm ²		
	1 x 14 AWG / 2 x 17 AWG	1 x 10 AWG / 2 x 12 AWG	1 x 8 AWG / 2 x 10 AWG	1 x 6 AWG / 2 x 8 AWG	1 x 4 AWG / 2 x 6 AWG	1 x 3 AWG / 2 x 6 AWG	
Maximum allowed section	1 x 25 mm ² / 2 x 16 mm ² 1 x 3 AWG / 2 x 6 AWG						
Tightening torque	2,5-3 Nm (22-26,6lb-in)						
<i>Note: Use 75°C (167°F) copper (CU), multi-stranded conductors</i>							

CONTROL/SIGNAL TERMINALS	
Rigid/flexible / cable lug conductor cross section	
1 Conductor section 2 Conductors section	1 x 0.2-0.75 mm ² 2 x 0.1-0.5 mm ²
	1 x 24-18 AWG 2 x 27-20 AWG
Stripping length	8 mm
<i>Note: Use 60/75°C (140/167°F) copper (CU), multi-stranded conductors</i>	

EXTRARAPID FUSES

GRZ Model	Nominal current	Model and fuse size (manufacturer Bussmann Div Cooper (UK) Ltd)	Fuse order code (descr.)	Fuse holder order code (descr.)
10	10	FWC-10A10F 10x38	338238 (FUS-010-L)	337132 (PF-10x38)
15	16	FWC-16A10F 10x38	338470 (FUS-016)	
20,20I	20	FWC-20A10F 10x38	338469 (FUS-020)	
25,25I	25	FWC-25A10F 10x38	338474 (FUS-025)	
30,30I	32	FWC-32A10F 10x38	338483 (FUS-032)	
40,40I	40	FWP-40A14F 14x51	338147 (FUS-040)	337131 (PF-14x51)
50	50	FWP-50A14F 14x51	338079 (FUS-051)	337130 (PF-22x58)
65	63	FWP-63A22F 22x58	338191 (FUS-063)	
75	80	FWP-80A22F 22x58	338199 (FUS-080)	

PROTECTION WITH MCB

Protection co-ordination (Type 2) with Siemens Miniature Circuit Breaker (MCB / Thermal-Magnetic) 5SY4 series, curve A, 3P			
Current size model (I2t)	3P MCB model (MCB Nominal current in A) at 400Vac	Wire cross sectional area (mm²)	Minimum length *of copper wire conductor (m)
GRZ(-H)-... 2S-15 2S-25 2S-30 3S-10 3S-20 3S-25 3S-40 (1800 A2s)	5SY4310-5 (10)	1,0	6,0
		1,5	10,0
		2,5	14,0
	5SY4316-5 (16)	1,0	6,0
		1,5	10,0
		2,5	14,0
		4,0	25,0
	5SY4320-5 (20)	1,5	10,0
		2,5	21,0
		4,0	30,0
	5SY4325-5 (25)	2,5	18,0
		4,0	30,0
5SY4332-5 (32)	2,5	36,0	
GRZ(-H)-... 2S-25I 2S-30I 2S-40I 2S-50 2S-75 3S-20I 3S-25I 3S-30I 3S-40I 3S-65 (12800 A2s)	For MCBs smaller than those indicated in the lines below, there are no section and length constraints.		
	5SY4332-5 (32)	2,5	2,0
		4,0	4,0
		6,0	7,0
	5SY4340-5 (40)	4,0	4,0
		6,0	7,0
		10,0	10,0
	5SY4350-5 (50)	6,0	7,0
		10,0	10,0
		16,0	18,0
	5SY4363-5 (63)	6,0	7,0
		10,0	10,0
		16,0	18,0

*The sizing is valid for a 400Vac phase-to-phase line with an assumed short-circuit current of 5KA

** Between MCB and Load plus return path which goes back to MCB.

Example, for a GRZ(-H)-...2S-50-..., with line voltage of 400Vac, controlled load of 45 A nominal for each leg, with a section of 6mm² of cable, an MCB 5SY4350-5 (50 A) the minimum length of the cables is 7m (cable length is intended between MCB and load, including return to MCB).

ORDER CODE

GRZ-H-3P - - - - - 0

Controlled phases	
3PH, 2 controlled 1 direct	2S
3PH, 3 controlled	3S

Nominal current	
for 2S (3PH, 2 controlled 1 direct) models	
15Aac	15
25Aac	25
25Aac I2t++	25I
30Aac	30
30Aac I2t++	30I
40Aac I2t++	40I
40Aac (Fan required)	40
50Aac (Fan required)	50
75Aac (Fan required)	75
for 3S (3PH, 3 controlled) models	
10Aac	10
20Aac	20
20Aac I2t++	20I
25Aac	25
25Aac I2t++	25I
30Aac I2t++	30I
40Aac (Fan required)	40
40Aac I2t++ (Fan required)	40I
65Aac (Fan required)	65

Nominal voltage	
480 Vac	48
600 Vac	60

0	
---	--

0	
---	--

Opzioni di diagnostica (*)	
0	None
1	Thermal alarm and Load Diagnostic insulated contact (NO) (1)
2	Thermal alarm and Load Diagnostic insulated contact (NC)
3	Thermal alarm and Load Diagnostic Digital output PNP (1)

Control type	
D	6 ... 32 Vdc
A	20 ... 260 Vac / Vdc

Notes:

(*) Over temperature protection always included
Load Diagnostic : No line voltage, Current fault.

(1) Not available for control type option A

EMC STANDARDS

EMC emissions

AC semiconductor motor controllers and conductors for non-motor loads	EN 60947-4-3	Class A Group 2
-----------------------------------------------------------------------	--------------	-----------------

EMC Immunity

Generic standards, immunity standard for industrial environments	EN 60947-4-3	
ESD immunity	EN 61000-4-2	4 kV contact discharge 8 kV air discharge
RF interference immunity	EN 61000-4-3 /A1	10 V/m amplitude modulated 80 MHz-1 GHz 10 V/m amplitude modulated 1.4 GHz-2 GHz
Conducted disturbance immunity	EN 61000-4-6	10 V/m amplitude modulated 0.15 MHz-80 MHz
Burst immunity	EN 61000-4-4	2 kV power line 2 kV I/O signal line
Surge immunity	EN 61000-4-4/5	Power line-line 1 kV Power line-earth 2 kV Signal line-earth 2 kV Signal line-line 1 kV
Magnetic fields immunity	Test are not required. Immunity is demonstrated by the successfully completion of the operating capability test	
Voltage dips, short interruptions and voltage immunity tests	EN 61000-4-11	100%U, 70%U, 40%U

LVD safety

Safety requirements for electrical equipment for measurement, control and laboratory use	EN 61010-1
------------------------------------------------------------------------------------------	------------

CAUTION

This product has been designed for class A equipment. Its use in a domestic environment may cause radio interference, in which case the user may be required to use additional attenuation methods.



WARNING

Read the following warnings before installing, connecting or using the device:

- follow instructions precisely when connecting the device.
- always use cables that are suitable for the voltage and current levels indicated in the technical specifications.
- In applications with risk of damage to persons, machines or materials, you **MUST** install auxiliary alarm devices.
- It is advisable to verify frequently that the alarm device is functional even during the normal operation of the equipment.
- **DO NOT** operate the device in rooms with dangerous (flammable or explosive) atmosphere.
- During continuous operation, the heat sink can reach up to 100°C, and stays at a high temperature even after the device is turned off due to thermal inertia; therefore, **DO NOT** touch it and avoid contact with electrical wires.
- do not work on the power part without first disconnecting electrical power to the panel.
- do not remove the cover when the device is powered!

Installation:

- correctly ground the device using the specific terminal.
- power supply lines must be separated from device input and output lines; always check that the supply voltage matches the voltage indicated on the device label.
- avoid dust, humidity, corrosive gases and heat sources.
- respect the installation distances between one device and another (to allow for dissipation of generated heat).
- to keep air in movement, we advise you to install a fan near the GRZ(-H) group in the electrical panel containing the GRZ(-H).
- respect the indicated dissipation curves

Maintenance:

at regular intervals, check operation of the cooling fans and clean all air ventilation filters.

- repairs must be done out only by trained and specialized personnel. Cut power to the device before accessing internal parts.
- do not clean the box with solvents derived from hydrocarbons (trichloroethylene, gasoline, etc.). Using such solvents will compromise the device's mechanical reliability. Use a clean cloth moistened with ethyl alcohol or water to clean external parts in plastic.

Service:

GEFRAN has a service department. The warranty excludes defects caused by any use not conforming to these instructions.

GEFRAN spa reserves the right to make aesthetic or functional changes at any time and without notice.



This device conforms to European Union Directive 2014/30/EU and 2014/35/EU as amended with reference to generic standards: **EN 61000-6-2** (immunity in industrial environment) **EN 61000-6-4** (emission in industrial environment) - **EN 61010-1** (safety regulations).



cULus listed, Conformity UL508 - File: E243386